



EasiPLUS
MI 3000
Instruction manual
Version 1.0, Code No. 20 750 977

Distributor:

Manufacturer:

METREL d.d.
Ljubljanska cesta 77
1354 Horjul
Slovenia

web site: <http://www.metrel.si>
e-mail: metrel@metrel.si

© 2006 METREL



Mark on your equipment certifies that this equipment meets the requirements of the EU (European Union) concerning safety and interference causing equipment regulations.

No part of this publication may be reproduced or utilized in any form or by any means without permission in writing from METREL.

1	Preface	5
2	Safety and operational considerations	6
2.1	Warnings and notes.....	6
2.2	Battery	9
2.3	Charging	9
2.4	Charging of new battery or unused battery.....	9
2.5	Standards applied.....	10
3	Instrument description	12
3.1	Front panel	12
3.2	Connector panel	13
3.3	Back panel.....	13
3.4	Bottom view	14
3.5	Carrying the instrument	15
3.6	Instrument set and accessories	16
4	Instrument operation	17
4.1	Meaning of symbols and messages on the instrument display	17
4.1.1	The online voltage and output terminal monitor	17
4.1.2	Message field – battery status	18
4.1.3	Message field – measurement warnings/messages	18
4.1.4	Result field.....	19
4.1.5	Other messages	19
4.1.6	Sound warnings.....	19
4.1.7	Function and parameter line	20
4.2	Selecting measurement function / sub-function	20
4.3	Setting measurement parameters and limits	20
4.4	Setup menu	20
4.4.1	Supply system setup.....	21
4.4.2	Language selection.....	21
4.4.3	Recalling original settings	21
4.5	Display contrast adjustment.....	22
5	Measurements	23
5.1	Insulation resistance	23
5.2	Continuity.....	25
5.2.1	Low Ω resistance	25
5.2.2	Continuity.....	25
5.3	Testing RCDs	29
5.3.1	Limit contact voltage	29
5.3.2	Nominal differential trip-out current.....	29

5.3.3	Multiplier of nominal residual current	29
5.3.4	RCD type and test current starting polarity	29
5.3.5	Testing selective (time-delayed) RCDs.....	30
5.3.6	Contact voltage.....	30
5.3.7	Trip-out time	31
5.3.8	Trip-out current	33
5.3.9	Autotest	34
5.4	Fault loop impedance and prospective fault current	38
5.4.1	Fault loop impedance	38
5.4.2	Trip-lock function	39
5.5	Line impedance and prospective short-circuit current.....	41
5.6	Phase sequence testing	43
5.7	Voltage and frequency.....	45
5.8	Testing PE terminal	47
6	Maintenance	49
6.1	Replacing fuses	49
6.2	Cleaning	49
6.3	Periodic calibration	49
6.4	Service.....	49
7	Technical specifications	50
7.1	Insulation resistance	50
7.2	Continuity resistance	50
7.2.1	Low Ω resistance	50
7.2.2	Continuity.....	51
7.3	RCD testing	51
7.3.1	General data.....	51
7.3.2	Contact voltage.....	52
7.3.3	Trip-out time	52
7.3.4	Trip-out current.....	52
7.4	Fault loop impedance and prospective fault current	53
7.5	Line impedance and prospective short-circuit current.....	54
7.6	Phase rotation.....	54
7.7	Voltage and frequency.....	54
7.8	Online voltage monitor.....	55
7.9	General data.....	55
8	Appendix A.....	56
8.1	Accessories required for specific measurement	56

1 Preface

Congratulations on your purchase of the EasiPLUS instrument and its accessories from METREL. The instrument was designed on basis of rich experience, acquired through many years of dealing with electric installation test equipment.

The EasiPLUS instrument is professional, multifunctional, hand-held test instrument intended for all measurements performed for total inspection of electrical installations in buildings. The following measurements and tests can be performed:

- q Voltage and frequency,
- q Continuity (Low Ω and continuity function),
- q Insulation resistance,
- q RCD testing,
- q Fault loop impedance,
- q Line impedance,
- q Phase sequence.

Wide graphic matrix display with backlight offers easy to read results, indications, measurement parameters and messages. Operation is simple and clear – operator does not need any special training (except reading this instruction manual) to operate the instrument.

In order for operator to be familiar enough with measurements in general and typical applications, it is advisable to read Metrel handbook *Measurements on electric installations in theory and practice*.

The instrument is equipped with all accessories necessary for comfortable testing. It is kept in a soft carrying bag together with all accessories.

2 Safety and operational considerations

2.1 Warnings and notes

In order to reach high level of operator's safety while carrying out various tests and measurements using the EasiPLUS instrument, as well as to keep the test equipment undamaged, it is necessary to consider the following general warnings:

- q  symbol on the instrument means »Read the Instruction manual with special care«. The symbol requires an action!
- q If the test equipment is used in a manner not specified in this user manual the protection provided by the equipment may be impaired!
- q Read this user manual carefully, otherwise use of the instrument may be dangerous for the operator, for the instrument or for the equipment under test!
- q Do not use the instrument and accessories if any damage is noticed!
- q In case a fuse has blown follow the instructions in this manual to replace it!
- q Consider all generally known precautions in order to avoid risk of electric shock while dealing with hazardous voltages!
- q Do not use the instrument in supply systems with voltages higher than 550 V!
- q Service intervention or adjustment procedure is allowed to be carried out only by a competent authorized person!
- q Use only standard or optional test accessories supplied by your distributor!
- q Consider that older and some of new optional test accessories compatible with this instrument meet only overvoltage category CAT III / 300 V! It means that maximal allowed voltage between test terminals and ground is 300 V!
- q Instrument contains rechargeable Ni-Cd or Ni-MH batteries. The batteries should only be replaced with the same type as defined on the battery placement label or in this manual. Do not use standard batteries while power supply adapter is connected, otherwise they may explode!
- q Hazardous voltages exist inside the instrument. Disconnect all test leads, remove the power supply cable and switch off the instrument before removing battery compartment cover.
- q Do not connect any voltage source on CLAMP CURRENT input. It is intended only for connection of current clamp with current output. Maximal continuous input current is 30 mA!
- q All normal safety precautions have to be taken in order to avoid risk of electric shock when working on electrical installations!

Warnings related to measurement functions

Insulation resistance

- q Insulation resistance measurement should only be performed on de-energized objects!
- q When measuring insulation resistance between installation conductors all loads must be disconnected and all switches closed!
- q Do not touch the test object during the measurement or before it is fully discharged! Risk of electric shock!
- q When an insulation resistance measurement has been performed on a capacitive object automatic discharge may not be done immediately! Warning message  and actual voltage is displayed during discharge, until voltage drops below 10 V.
- q Do not connect test terminals to external voltage higher than 600 V (AC or DC) in order not to damage the test instrument!

Continuity functions

- q Continuity measurements should only be performed on de-energized objects!
- q Test result may be influenced because of parallel impedances or transient currents!

Testing PE terminal

- q If phase voltage is detected on tested PE terminal, stop all measurements immediately and take care the fault is eliminated before proceeding with any activity!

Notes related to measurement functions

General

- q Indicator  means that the selected measurement cannot be performed because of irregular conditions on input terminals.
- q Insulation resistance, continuity functions and earth resistance measurements shall be performed on de-energized objects.
- q PASS / FAIL indication is enabled when limit is set. Apply appropriate limit value for evaluation of measurement results.
- q In case that only two of three wires are connected to tested electrical installation, only voltage indication between these two wires is valid.

Insulation resistance

- q In case of voltage higher than 10 V (AC or DC) between test terminals, the insulation resistance measurement will not be performed.

Continuity functions

- q If voltage between test terminals is higher than 10 V the continuity functions cannot be performed.
- q Before performing continuity measurement compensate test lead resistance if necessary. The compensation is performed in **LowW** function.

RCD functions

- q The instrument indicates reverse polarity and disables measurement if L/L1 and N/L2 test leads (universal test cable) are connected in reversed way, or terminals of the tested wall socket are reversed.
- q Parameter settings in one function are also kept for other RCD functions!
- q The measurement of contact voltage does not normally trip an RCD. However, the trip limit may be exceeded as a result of leakage current flowing to the PE protective conductor or a capacitive connection between L and PE conductors.
- q Trip-lock sub-function (function selector switch in **LOOP** position) takes longer to complete but offers much better accuracy of fault loop impedance result (in comparison with the R_L sub-result in **Contact voltage** function).
- q RCD trip-out time and RCD trip-out current measurements will be performed only if contact voltage in pre-test at nominal differential current is lower than the set limit contact voltage!
- q The auto test sequence (RCD AUTO function) stops when trip-out time is out of allowed period.

Fault loop impedance functions

- q The instrument indicates reverse polarity and disables measurement if L/L1 and N/L2 test leads (universal test cable) are connected in reversed way, or terminals of the tested wall socket are reversed.
- q Specified accuracy of tested parameters is valid only if mains voltage is stable during the measurement.
- q Fault loop impedance measurement trips an RCD.
- q The measurement of fault loop impedance using trip-lock function does not normally trip an RCD. However, the trip limit may be exceeded because of leakage current flowing to the PE protective conductor or a capacitive connection between L and PE conductors.

Line impedance

- q The instrument indicates reverse polarity and disables measurement if L/L1 and N/L2 test leads (universal test cable) are connected in reversed way, or terminals of the tested wall socket are reversed.
- q Specified accuracy of tested parameters is valid only if mains voltage is stable during the measurement.

Testing PE terminal

- q PE terminal can be tested in RCD, LOOP and LINE function selector switch positions only!
- q For correct testing of PE terminal, the TEST key has to be touched for a few seconds.
- q Make sure to stand on non-isolated floor while carrying out the test otherwise, test result may be wrong!

2.2 Battery

- q  When battery cells have to be replaced, before opening battery/fuse compartment cover, disconnect any measuring accessory connected to the instrument and power off the instrument, hazardous voltage inside!
- q Insert cells correctly, otherwise the instrument will not operate and the batteries could be discharged.
- q If the instrument is not used for a long period remove all batteries from the battery compartment.
- q Alkaline or rechargeable Ni-Cd or Ni-MH batteries (size AA) can be used. The operating hours are given for cells with a nominal capacity of 2100 mAh.
- q Do not recharge alkaline battery cells!

2.3 Charging

The batteries are charged whenever the power supply adapter is connected to the instrument. In-built protection circuits control the charging procedure and assure maximal battery lifetime. Power supply socket polarity is shown in figure 2.1.



Figure 2.1: Power supply socket polarity

Note:

- q Use only power supply adapter delivered from manufacturer or distributor of the test equipment to avoid possible fire or electric shock!

2.4 Charging of new battery or unused battery

Unpredictable chemical processes can occur during charging of new batteries or batteries that were unused for a longer period (more than 3 months). Ni-MH and Ni-Cd batteries are affected to a various degree (sometimes called as memory effect). As a result, the instrument operation time can be significantly reduced at the initial charging/discharging cycles.

Therefore, it is recommended:

- q To completely charge the batteries (at least 14h with in-built charger).
- q To completely discharge the batteries (can be performed with normal work with the instrument).
- q Repeating the charge/discharge cycle for at least two times (four cycles are recommended).

When using external intelligent battery chargers one complete discharging/charging cycle is performed automatically.

After performing this procedure, a normal battery capacity is restored. The operation time of the instrument now meets the data in the technical specification.

Notes:

- q The charger in the instrument is a pack cell charger. This means that the batteries are connected in series during the charging so all batteries must be in similar shape (similarly charged, same type and age).
- q Even one deteriorated battery (or just of an another type) can cause an improper charging of the entire battery pack (heating of the battery pack, significantly decreased operation time).
- q If no improvement is achieved after performing several charging/discharging cycles the shape of individual batteries should be determined (by comparing battery voltages, checking them in a cell charger, etc). It is very likely that only some of the batteries are deteriorated.
- q The effects described above should not be mixed with normal battery capacity decrease over time. All charging batteries lose some of their capacity when repeatedly charged/discharged. The actual decrease of capacity versus number of charging cycles depends on battery type and is provided in the technical specification from battery manufacturer.

2.5 Standards applied

The EasiPLUS instrument is manufactured and tested in accordance with the following regulations:

Electromagnetic compatibility (EMC)

EN 61326	Electrical equipment for measurement, control and laboratory use – EMC requirements Class B (Hand-held equipment used in controlled EM environments)
----------	---

Safety (LVD)

EN 61010-1	Safety requirements for electrical equipment for measurement, control and laboratory use – Part 1: General requirements
EN 61010-31	Safety requirements for hand-held probe assemblies for electrical measurement and test

Functionality

EN 61557	Electrical safety in low voltage distribution systems up to 1000 V _{AC} and 1500 V _{AC} – Equipment for testing, measuring or monitoring of protective measures Part 1 General requirements Part 2 Insulation resistance Part 3 Loop resistance Part 4 Resistance of earth connection and equipotential bonding Part 6 Residual current devices (RCDs) in TT and TN systems Part 7 Phase sequence Part 10 Combined measuring equipment
----------	---

Other reference standards for testing RCDs

EN 61008	Residual current operated circuit-breakers without integral over current protection for household and similar uses
EN 61009	Residual current operated circuit-breakers with integral over current protection for household and similar uses
EN 60364-4-41	Electrical installations of buildings Part 4-41 Protection for safety – protection against electric shock
BS 7671	IEE Wiring Regulations

Note about EN and IEC standards:

- q Text of this manual contains references to European standards. All standards of EN 6XXXX (e.g. EN 61010) series are equivalent to IEC standards with the same number (e.g. IEC 61010) and differ only in amended parts required by European harmonization procedure.

3 Instrument description

3.1 Front panel

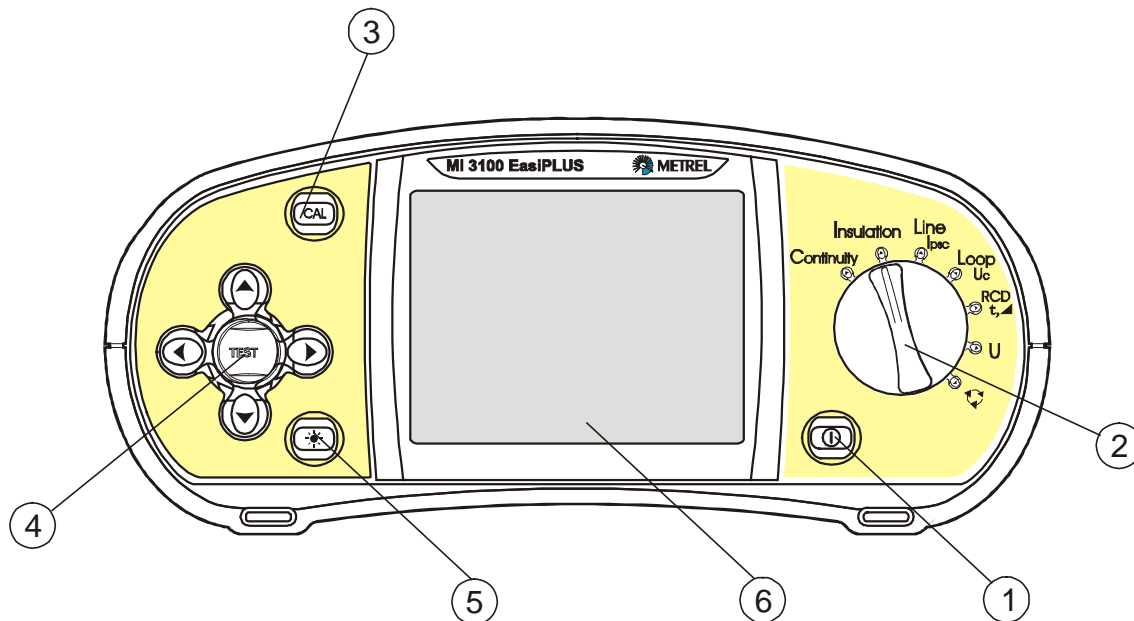

Figure 3.1: Front panel

Legend:

- 1 ON/OFF key, to switch on or off the instrument.
The instrument is automatically switched off 10 minutes after the last strike of any key or function switch rotation.
- 2 Function selector switch.
- 3 CAL key, to compensate test leads resistance in low-value resistance measurement.
- 4 Jogger keypad with cursors and TEST keys.
The TEST key also acts as the PE touching electrode.
- 5 BACKLIGHT and CONTRAST key, to change backlight level and contrast.
High level backlight is automatically shut off 20 seconds after the last strike of any key or function switch rotation in order to extend service life of the batteries.
- 6 128 × 64 dots matrix display with backlight.

3.2 Connector panel

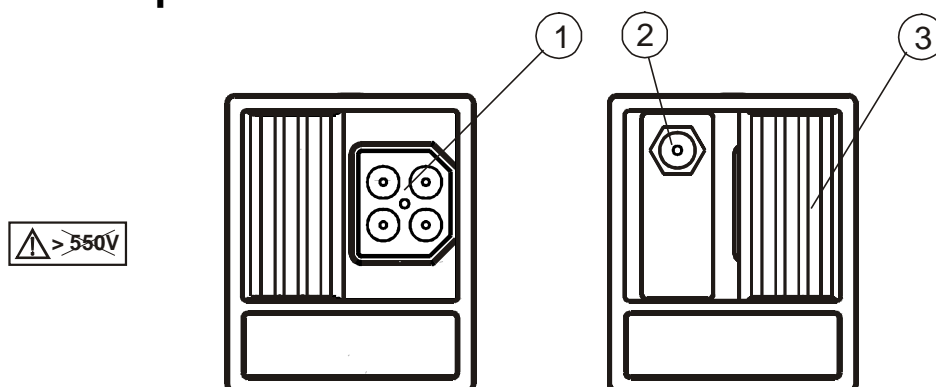

Figure 3.2: Connector panel

Legend:

1Test connector.

Warning! Maximum allowed voltage between test terminals and ground is 600 V! Maximum allowed voltage between test terminals is 550 V!

2Power supply socket.

3Protection connector cover.

3.3 Back panel

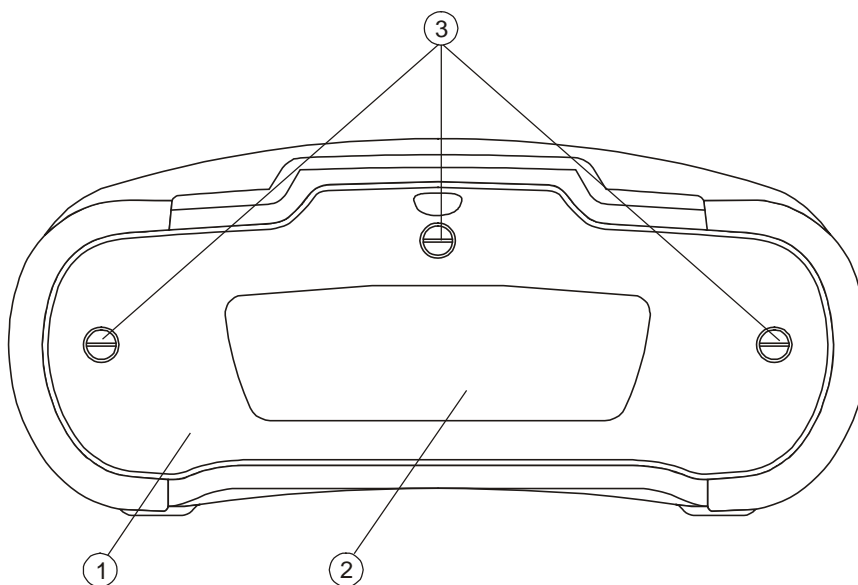

Figure 3.3: Back panel

Legend:

1Battery/fuse compartment cover.

2Information label.

3Fixing screws for battery/fuse compartment cover.

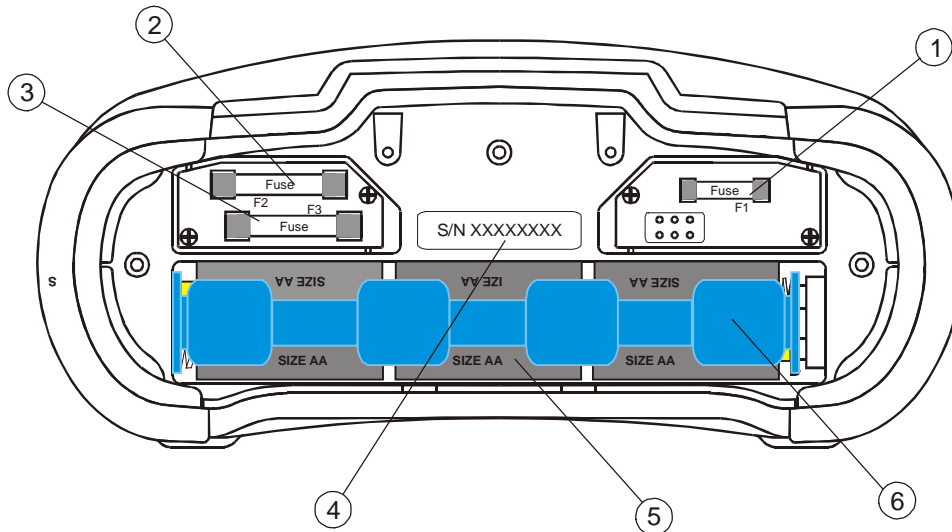

Figure 3.4.: Battery and fuse compartment

Legend:

- 1Fuse F1.
- 2Fuse F2.
- 3Fuse F3.
- 4Serial number label.
- 5Batteries (size AA).
- 6Battery holder.

3.4 Bottom view

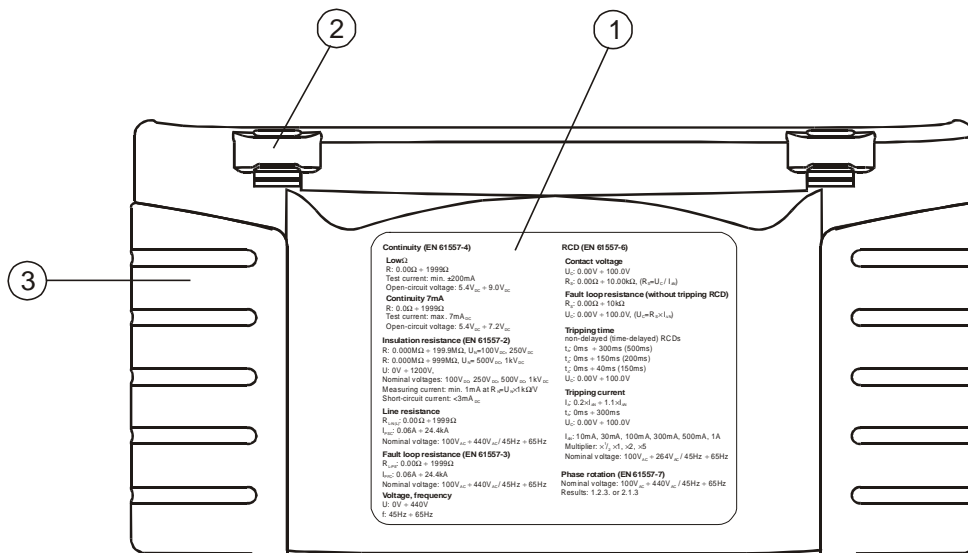

Figure 3.5: Bottom view

Legend:

- 1Information label.
- 2Neck belt openings.
- 3Handling side covers.

3.5 Carrying the instrument

With the neck-carrying belt supplied in standard set, various possibilities of carrying the instrument are available. Operator can choose appropriate one on basis of his operation, see the following examples:



The instrument is hung around operator's neck only - quick placing and displacing.



The instrument can be used even placed in soft carrying bag – test cable connected to the instrument through the front aperture.

3.6 Instrument set and accessories

Instrument	EasiPLUS – MI 3100 Soft carrying bag Soft carrying neck belt Soft carrying back belt
<i>Measuring accessories^{*)}</i>	Universal test cable (3 × 1.5 m) Mains measuring cable Test tip (blue) Test tip (black) Test tip (green) 3 alligator clips (black)
<i>Documentation</i>	Short instruction manual Product verification data Warranty declaration Declaration of conformity
<i>Battery</i>	6 Ni-MH rechargeable battery cells Power supply adapter
<i>CD-ROM</i>	Instruction manual Short instruction manual Measurement on electric installations in theory and practice
<i>Optional accessories^{*)}</i>	Tip commander Three-phase cable Three-phase adapter Test lead (black, 4 m) Test lead (black, 20 m) Test lead (black, 50 m) Fast 12 cells charger (C and AA accu sizes) Fast 6 cells charger (AA accu size)

^{*)} Please, see the attached sheet to compare received set of accessories with listed one. See also the attached sheet for a list of optional accessories that are available on request from your distributor.

4 Instrument operation

4.1 Meaning of symbols and messages on the instrument display

The instrument display is divided into four sections:

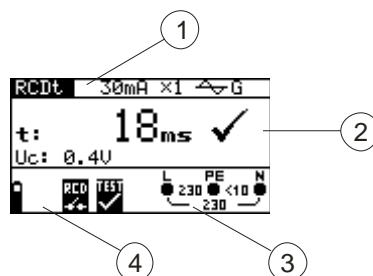
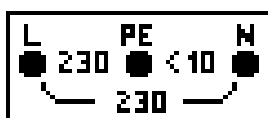

Figure 4.1: Display outlook

Legend:

- 1Function and parameter line.
In the top display line the measuring function/sub-function and parameters are displayed.
- 2Result field.
In this field the main result and sub-results together with the PASS/FAIL/ABORT status are displayed.
- 3Online voltage and output monitor.
- 4Message field.

4.1.1 The online voltage and output terminal monitor



Online voltage is displayed together with test terminal indication. All three test terminals are used for selected measurement.

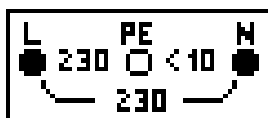

Online voltage is displayed together with test terminal indication. L and N test terminals are used for selected measurement.

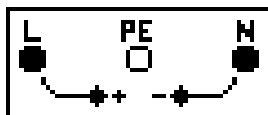

Polarity of test voltage applied to the output terminals, L and N.



Unknown supply system.

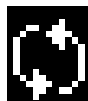

L – N polarity changed.



Frequency out of range.

4.1.2 Message field – battery status



Battery power indication.



Low battery indication. Battery pack is too weak to guarantee correct result. Replace the batteries.



Recharging is running (if power supply adapter is connected).

4.1.3 Message field – measurement warnings/messages

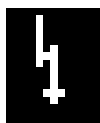

Warning! High voltage is applied to the test terminals.

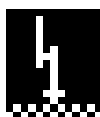

Warning! Phase voltage on the PE terminal! Stop all the measurements immediately and eliminate the fault before proceeding with any activity!



Measurement is running. Consider any displayed warnings!



Measurement can be performed after pressing the TEST key. Consider any displayed warning after starting the measurement!



Measurement prohibited. Consider any displayed warnings and check online voltage/terminal monitor!



Test leads resistance in low-value resistance measurement is compensated.

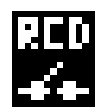

RCD tripped during the measurement. The trip limit may be exceeded as a result of leakage current flowing to the PE protective conductor or capacitive connection between L and PE conductors.



RCD not tripped during the measurement.

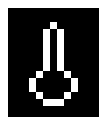

Instrument overheated. Temperature of internal components in the instrument reached top limit. Measurement is prohibited until the temperature is lower than that limit.



Battery capacity is too low to guarantee correct result. Replace the batteries.



Fuse F1 (continuity circuit) blown or not inserted.



Single fault condition in IT system.

4.1.4 Result field



Measurement passed.



Measurement failed.



Measurement is aborted. Check the conditions at the input terminal.

4.1.5 Other messages

Hard Reset	Instrument settings and measurement parameters/limits are set to initial (factory) values. For more information refer to chapter 4.5.5. <i>Recalling original settings.</i>
First measurement	First stored measurement results are displayed.
Last measurement	Last stored measurement results are displayed.
Memory full	All memory locations are occupied.
Already saved	Measurement results already saved.
CHECK SUM ERROR	RAM contents damaged. Contact your distributor or manufacturer for further information.

4.1.6 Sound warnings

The shortest sound	Pressed key deactivated. Sub-function is not available.
Short sound	Pressed key activated. Measurement has been started after pressing the TEST key. Consider any displayed warnings during measurement.
Long sound	Measurement is prohibited. Consider any displayed warnings and check online voltage/terminal monitor!
Periodic sound	Warning! Phase voltage on the PE terminal! Stop all the measurements immediately and eliminate the fault before proceeding with any activity!

4.1.7 Function and parameter line



Figure 4.2: Function selector switch and belonging parameter line

Legend:

- 1.....Main function name.
- 2.....Function or sub-function name.
- 3.....Measuring parameters and limit values.

4.2 Selecting measurement function / sub-function

The following measurements can be selected with the function selector switch:

- q Voltage and frequency,
- q Insulation resistance,
- q Low-value resistance,
- q RCD testing,
- q Fault loop impedance,
- q Line impedance,
- q Phase sequence.

The function / sub-function name is highlighted on the display by default. Sub-function can be selected by using \tilde{U} and \hat{U} keys in function / parameter line.

4.3 Setting measurement parameters and limits

By using \times and \emptyset keys select the parameter/limit value you want to edit. By using \tilde{U} and \hat{U} keys the selected parameter can be set.

Once the measurement parameters are set the settings are kept until new changes are made or the original settings are recalled.

4.4 Setup menu

In the **Setup** menu the following actions can be taken:

- q Supply system selection,
- q Prospective short/fault current scaling factor adjustment,
- q Language selection.

To enter the **Setup** menu press the  key and rotate function selector switch in any direction at the same time.

Rotate function selector switch again to leave **Setup** menu or its sub-menus.

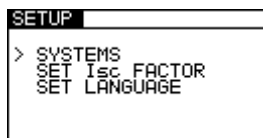

Figure 4.3: Setup menu

4.4.1 Supply system setup

The instrument enables tests and measurements on the following supply systems:

- q TN (TT) system,
- q IT system,
- q Reduced low voltage system (2×55 V),
- q Reduced low voltage system (3×63 V).

Select **SYSTEMS** in the **Setup** menu by using **Ū** and **Ū** keys and press the TEST key to enter the **Supply system** setup menu.

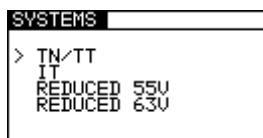

Figure 4.4: Supply systems selecting menu

By using **Ū** and **Ū** keys select supply system and press the TEST key to accept the setting.

4.4.2 Language selection

Select **SET LANGUAGE** in **Setup** menu by using the keys **Ū** and **Ū** and press the TEST key to enter the **Language** selecting menu.

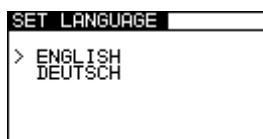

Figure 4.5: Language selecting menu

By using **Ū** and **Ū** keys select language you want to use. Press The TEST key to accept the new setting.

4.4.3 Recalling original settings

The following parameters and settings can be set to initial (factory) values:

- q Test parameters and limit values,
- q Contrast,
- q Supply system,

In order to recall original setting press and hold \emptyset key and switch on the instrument. »Hard reset« message will be displayed for a while.

Instrument settings, measurement parameters and limits are set to their initial values as follows:

Instrument settings	Default value
Contrast	50 %
Prospective short/fault current scaling factor	1.00
Supply system	TN/TT

Function Sub-function	Parameter / limit value
CONTINUITY	Selected function: R LOW Ω
R LOW Ω	High limit resistance value: 2.0 Ω
Continuity	High limit resistance value: 20.0 Ω
INSULATION	Nominal test voltage: 500 V Low limit resistance value: 1 M Ω
RCD	Selected function: RCD Uc
Contact voltage – RCD Uc Trip-out time – RCD t Trip-out current – RCD $I_{\Delta N}$ Autotest – RCD AUTO	Nominal differential current: $I_{\Delta N}=30$ mA RCD type and test current starting polarity: $\Delta \nabla$ G Limit contact voltage: 50 V Nominal differential current multiplier: $\times 1$

4.5 Display contrast adjustment

When low-level backlight is activated press and hold BACKLIGHT key until the **Display contrast** adjustment menu is displayed.

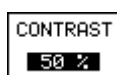

Figure 4.6: Contrast adjustment menu

Use \bar{U} and \bar{U} keys to adjust the contrast level. Press the TEST key to accept the new setting.

5 Measurements

5.1 Insulation resistance

Insulation resistance measurement is performed in order to assure safety against electric shock. Using this measurement the following items can be determined:

- Insulation resistance between installation conductors,
- Insulation resistance of non-conductive rooms (walls and floors),
- Insulation resistance of ground cables,
- Resistance of semi-conductive (antistatic) floors.

For additional general information concerning insulation resistance measurement refer to the Metrel handbook *Measurements on electric installations in theory and practice*.

How to perform insulation resistance measurement

Step 1 Select **Insulation** function with the function selector switch. The following menu is displayed:



Figure 5.1: Insulation resistance measurement menu

Connect test cable to the EasiPLUS instrument.

Step 2 Set the following measuring parameter and limit values:

- Nominal test voltage,
- Minimum insulation resistance.

Step 3 Connect test cable to the item under test. Follow the connection diagram shown in figure 5.2 to perform insulation resistance measurement.

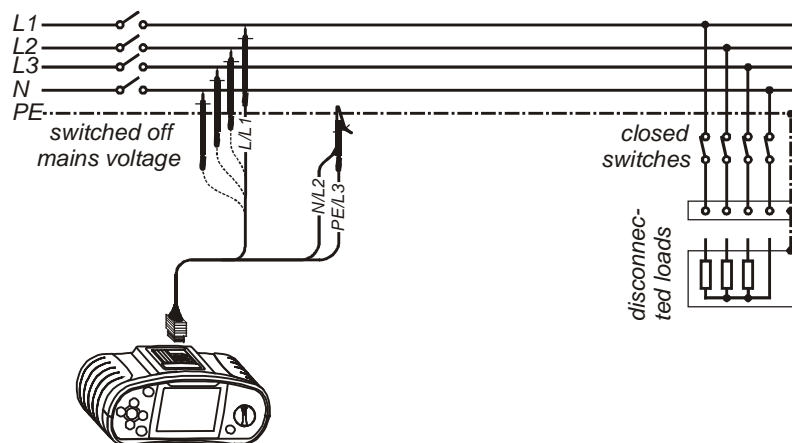

Figure 5.2: Connection of universal test cable

Step 4 Check the displayed warnings and online voltage/terminal monitor before starting the measurement. If OK, press and hold the TEST key until result is stabilised. Actual measured results are shown on the display during measurement.

After the TEST key is released the last measured results are displayed, together with the PASS/FAIL indication (if applicable).

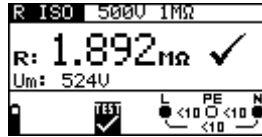



Figure 5.3: Example of insulation resistance measurement results

Displayed results:

R Insulation resistance,
Um Instrument test voltage.

Warnings:

- q Insulation resistance measurement should only be performed on de-energized objects!
- q When measuring insulation resistance between installation conductors all loads must be disconnected and all switches closed!
- q Do not touch the test object during the measurement or before it is fully discharged! Risk of electric shock!
- q When an insulation resistance measurement has been performed on a capacitive object automatic discharge may not be done immediately! Warning message  and actual voltage is displayed during discharge, until voltage drops below 10 V.
- q Do not connect test terminals to external voltage higher than 600 V (AC or DC) in order not to damage the test instrument!

Note:

- q In case of voltage higher than 10 V (AC or DC) between test terminals, the insulation resistance measurement will not be performed.

5.2 Continuity

Two **Continuity** sub-functions are available:

- Low Ω resistance,
- Continuity.

5.2.1 Low Ω resistance

This test is used to ensure electric safety and correct connection of all protective conductors, earth conductors or bonding conductors. The measurement of Low Ω resistance is performed with automatic pole reversal of the test voltage and the test current of more than 200mA. This measurement completely complies with EN 61557-4 regulations.

5.2.2 Continuity

Continuous low-value resistance measurement can be performed without pole reversal of the test voltage and a lower test current (few mA). In general, function serves as an ordinary Ω -meter with low-test current. Function can also be used to test inductive components.

For additional information concerning continuity measurement refer to the Metrel handbook *Measurements on electric installations in theory and practice*.

How to perform Low Ω resistance measurement

Step 1 Select **Continuity** function with the function selector switch first. Use the \bar{U}/\bar{U} keys to select **R LOW Ω** function. The following menu is displayed:

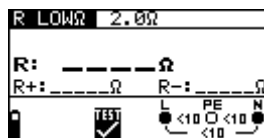

Figure 5.4: Low Ω resistance measurement menu

Connect test cable to the EasiPLUS instrument.

Step 2 Set the following limit value:

- High limit resistance value.

Step 3 Before performing Low Ω measurement compensate test leads resistance as follows:

1. Short test leads first as shown in figure 5.11.

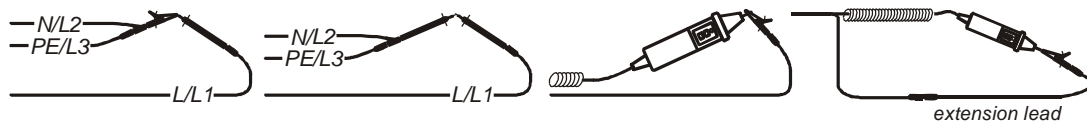

Figure 5.5: Shorted test leads

2. Press the TEST key in order to perform regular measurement. Result close to 0.00 Ω is displayed.
3. Press the CAL key. After performing test leads compensation compensated test leads indicator is displayed as **Co** in function and parameter line.
4. In order cancel existing compensation follow the procedure described in this step with open test leads. The compensation indicator **Co** will disappear after cancelling compensation.

Compensation performed in this function is also considered in the **Continuity** measurement.

Step 4 Connect test cable to the item under test. Follow the connection diagram shown in figures 5.12 and 5.13 to perform **LowW resistance** measurement.

MPEC....Main Potential Equilizing Collector
PCC....Protection Conductor Collector

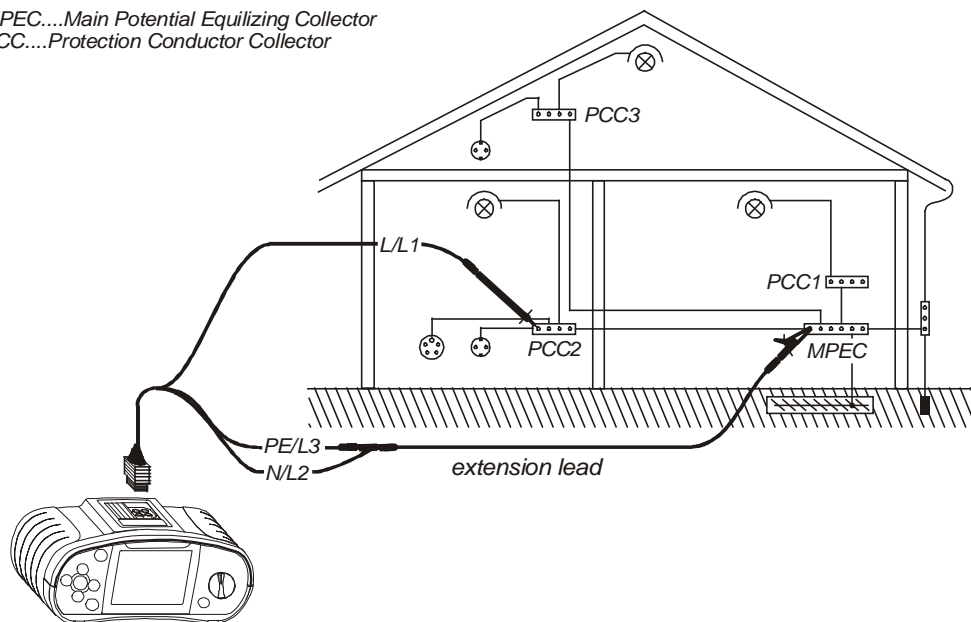

Figure 5.6: Connection of universal test cable and optional probe test lead

Step 5 Check the displayed warnings and online voltage/terminal monitor before starting measurement. If OK, press the TEST key. After performing the measurement, results appear on the display together with the PASS/FAIL indication (if applicable).

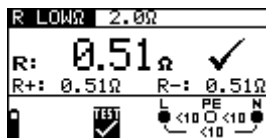

Figure 5.7: Example of LowΩ resistance measurement results

Displayed results:

- R** Main LowΩ resistance result (average of R+ and R- results),
- R+** LowΩ resistance sub-result with positive voltage at L terminal,
- R-** LowΩ resistance sub-result with positive voltage at N terminal.

Warnings:

- ⚠ Low-value resistance measurement should only be performed on de-energized objects!
- ⚠ Test result may be influenced because of parallel impedances or transient currents!

Note:

- ⚠ If voltage between test terminals is higher than 10 V then the R LowΩ measurement will not be performed.

How to perform Continuity measurement

Step 1 Select **Continuity** function with the function selector switch first. Use the \bar{U}/\bar{U} keys to select **Continuity** function. The following menu is displayed:

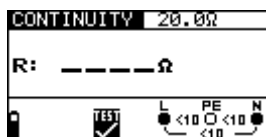

Figure 5.8: Continuity measurement menu

Connect test cable to the EasiPLUS instrument.

Step 2 Set the following limit value:

- ⚠ High limit resistance value.

Step 3 Connect test cable to the item under test. Follow the connection diagram shown in figures 5.16 and 5.17 to perform **Continuity** measurement.

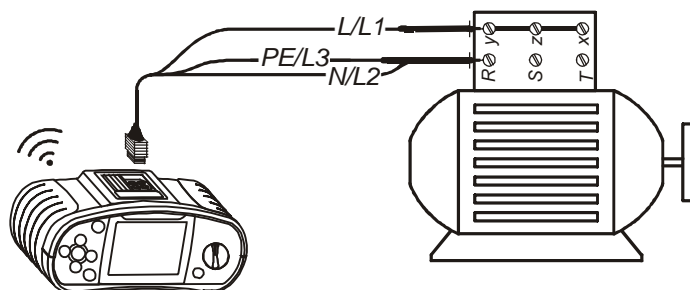

Figure 5.9: Connection of universal test cable

Step 4 Check the displayed warnings and online voltage/terminal monitor before starting measurement. If OK, press the TEST key to start the measurement. Actual measuring result with PASS/FAIL indication (if applicable) is shown on the display during measurement.

To stop measurement at any time press the TEST key again. The last measured result is displayed, together with the PASS/FAIL indication (if applicable).

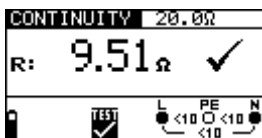

Figure 5.10: Example of Continuity measurement result

Displayed result:

R Continuity resistance result.

Warning:

- Continuity measurement should only be performed on de-energized objects!

Notes:

- If voltage between test terminals is higher than 10 V the continuity measurement cannot be performed.
- Before performing continuity measurement, compensate test lead resistance if necessary. The compensation is performed in **LowW** function.

5.3 Testing RCDs

When testing RCDs, the following sub-functions can be performed:

- q Contact voltage measurement,
- q Trip-out time measurement,
- q Trip-out current measurement,
- q RCD autotest.

In general, the following parameters and limits can be set when testing RCDs:

- q Limit contact voltage,
- q Nominal differential RCD trip-out current,
- q Multiplier of nominal differential RCD trip-out current,
- q RCD type,
- q Test current starting polarity.

5.3.1 Limit contact voltage

Safety contact voltage is limited to 50 V_{AC} for standard domestic area. In special environments (hospitals, wet places, etc.) contact voltages up to 25 V_{AC} are permitted. Limit contact voltage can be set in **Contact voltage** function only!

5.3.2 Nominal differential trip-out current

Nominal residual current is the RCD rated trip-out current. The following RCD current ratings can be set: 10 mA, 30 mA, 100 mA, 300 mA, 500 mA and 1000 mA.

5.3.3 Multiplier of nominal residual current

Selected nominal differential current can be multiplied by ½, 1, 2 or 5.

5.3.4 RCD type and test current starting polarity

EasiPLUS instrument enables testing of general (non-delayed) and selective (time-delayed, marked with \boxed{S} symbol) RCDs, which are suited for:

- q Alternating residual current (AC type, marked with \sphericalangle symbol),
- q Pulsating DC residual current (A type, marked with \frown symbol).

Test current starting polarity can be started with the positive half-wave at 0° or with the negative half-wave at 180°.

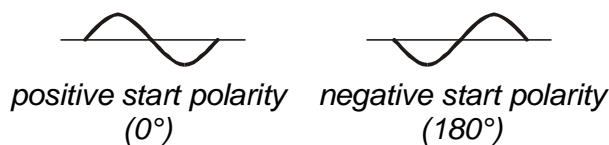

Figure 5.11: Test current started with the positive or negative half-wave

5.3.5 Testing selective (time-delayed) RCDs

Selective RCDs demonstrate delayed response characteristics. Trip-out performance is influenced due to the pre-loading during measurement of contact voltage. In order to eliminate pre-loading a time delay of 30 s is inserted before performing trip-out test.

5.3.6 Contact voltage

Leakage current flowing to the PE terminal causes a voltage drop across earth resistance, which is called contact voltage. This voltage is presented on all accessible parts connected to the PE terminal and should be lower than the safety limit voltage.

The parameter contact voltage is measured without tripping-out the RCD. R_L is a fault loop resistance and is calculated as follows:

$$R_L = \frac{U_C}{I_{\Delta N}}$$

Displayed contact voltage relates to the rated nominal differential current of the RCD and is multiplied by a factor because of safety. See the table 5.1 for detailed contact voltage calculation.





RCD type	Contact voltage U_C
	$U_C \propto 1.05 \times I_{\Delta N}$
	$U_C \propto 1.05 \times 2 \times I_{\Delta N}$
	$U_C \propto 1.05 \times \sqrt{2} \times I_{\Delta N}$
	$U_C \propto 1.05 \times 2 \times \sqrt{2} \times I_{\Delta N}$

Table 5.1: Relationship between U_C and I_{DN}

For additional general information concerning contact voltage measurement, refer to the Metrel handbook *Measurements on electric installations in theory and practice*.

How to perform contact voltage measurement

Step 1 Select **RCD** function with the function selector switch first. Use the \bar{U}/\bar{U} keys to select **Contact voltage** function. The following menu is displayed:

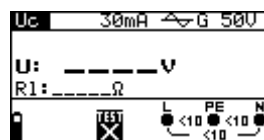

Figure 5.12: Contact voltage measurement menu

Connect test cable to the EasiPLUS instrument.

Step 2 Set the following measuring parameters and limit values:

- Nominal residual current,
- RCD type,
- Limit contact voltage.

Step 3 Follow the connection diagram shown in figure 5.21 to perform contact voltage measurement.

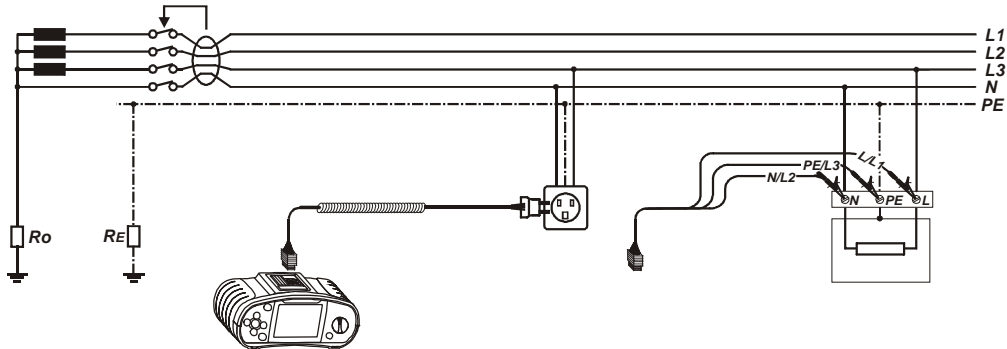

Figure 5.13: Connection of plug test cable or universal test cable

Step 4 Check the displayed warnings and online voltage/terminal monitor before starting the measurement. If OK, press the TEST key. After performing the measurement, results with PASS/FAIL indication appear on the display.



Figure 5.14: Example of contact voltage measurement results

Displayed results:

U Contact voltage.

RI Fault loop resistance.

Notes:

- Parameter settings are kept in other RCD functions!
- The measurement of contact voltage does not normally trip an RCD. However, the trip limit may be exceeded as a result of leakage current flowing to the PE protective conductor or a capacitive connection between L and PE conductors.
- Trip-lock sub-function (function selector switch in **LOOP** position) takes longer to complete but offers much better accuracy of fault loop impedance result (in comparison with the R_L sub-result in **Contact voltage** function).

5.3.7 Trip-out time

Trip-out time measurement is used to verify the effectiveness of the RCD. This is achieved by a test simulating an appropriate fault condition. Trip-out times vary between standards and are listed below.

Trip-out times according to EN 61008 / EN 61009:

	$\frac{1}{2} \times I_{\Delta N}^{*)}$	$I_{\Delta N}$	$2 \times I_{\Delta N}$	$5 \times I_{\Delta N}$
General (non-delayed) RCDs	$t_{\Delta} > 300 \text{ ms}$	$t_{\Delta} < 300 \text{ ms}$	$t_{\Delta} < 150 \text{ ms}$	$t_{\Delta} < 40 \text{ ms}$
Selective (time-delayed) RCDs	$t_{\Delta} > 500 \text{ ms}$	$130 \text{ ms} < t_{\Delta} < 500 \text{ ms}$	$60 \text{ ms} < t_{\Delta} < 200 \text{ ms}$	$50 \text{ ms} < t_{\Delta} < 150 \text{ ms}$

Trip-out times according to IEC 60364-4-41:

	$\frac{1}{2} \times I_{\Delta N}^{*)}$	$I_{\Delta N}$	$2 \times I_{\Delta N}$	$5 \times I_{\Delta N}$
General (non-delayed) RCDs	$t_{\Delta} > 999 \text{ ms}$	$t_{\Delta} < 999 \text{ ms}$	$t_{\Delta} < 150 \text{ ms}$	$t_{\Delta} < 40 \text{ ms}$
Selective (time-delayed) RCDs	$t_{\Delta} > 999 \text{ ms}$	$130 \text{ ms} < t_{\Delta} < 999 \text{ ms}$	$60 \text{ ms} < t_{\Delta} < 200 \text{ ms}$	$50 \text{ ms} < t_{\Delta} < 150 \text{ ms}$

Trip-out times according to BS 7671:

	$\frac{1}{2} \times I_{\Delta N}^{*)}$	$I_{\Delta N}$	$2 \times I_{\Delta N}$	$5 \times I_{\Delta N}$
General (non-delayed) RCDs	$t_{\Delta} > 1999 \text{ ms}$	$t_{\Delta} < 300 \text{ ms}$	$t_{\Delta} < 150 \text{ ms}$	$t_{\Delta} < 40 \text{ ms}$
Selective (time-delayed) RCDs	$t_{\Delta} > 1999 \text{ ms}$	$130 \text{ ms} < t_{\Delta} < 500 \text{ ms}$	$60 \text{ ms} < t_{\Delta} < 200 \text{ ms}$	$50 \text{ ms} < t_{\Delta} < 150 \text{ ms}$

^{*)} Test current of $\frac{1}{2} \times I_{\Delta N}$ cannot cause trip-out of the RCDs.

For additional general information concerning trip-out time measurement, refer to the Metrel handbook *Measurements on electric installations in theory and practice*.

How to perform trip-out time measurement

Step 1 Select **RCD** function with the function selector switch first. Use the keys \bar{U}/\bar{U} to select **Trip-out time** function. The following menu is displayed:

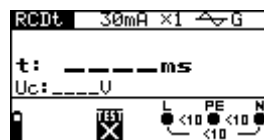

Figure 5.15: Trip-out time measurement menu

Connect test cable to the EasiPLUS instrument.

Step 2 Set the following measuring parameters:

- q Nominal differential trip-out current,
- q Nominal differential trip-out current multiplier,
- q RCD type, and
- q Test current starting polarity.

Step 3 Follow the connection diagram shown in figure 5.21 (see the chapter 5.4.6 *Contact voltage*) to perform trip-out time measurement.

Step 4 Check the displayed warnings and online voltage/terminal monitor before starting measurement. If OK, press the TEST key. After performing the measurement results with PASS/FAIL indication appear on the display.



Figure 5.16: Example of trip-out time measurement results

Displayed results:

t..... Trip-out time,
U_c..... Contact voltage.

Notes:

- q Parameter settings are kept in other RCD functions!
- q Trip-out time measurement will be performed only if contact voltage at nominal differential current is lower than the set limit contact voltage!
- q The measurement of contact voltage in pre-test does not normally trip an RCD. However, the trip limit may be exceeded because of leakage current flowing to the PE protective conductor or a capacitive connection between L and PE conductors.

5.3.8 Trip-out current

A continuously rising residual current is used for the evaluation of an RCD. After the measurement has been started, the test current generated by the instrument is continuously increased, starting at $0.2 \times I_{\Delta N}$ to $1.1 \times I_{\Delta N}$ (to $1.5 \times I_{\Delta N}$ for pulsating DC residual currents), until the RCD is tripped.

For additional general information concerning trip-out current measurement refer to the Metrel handbook *Measurements on electric installations in theory and practice*.

How to perform trip-out current measurement

Step 1 Select **RCD** function with the function selector switch first. Use the keys \bar{U}/\bar{U} to select **Trip-out current** function. The following menu is displayed:



Figure 5.17: Trip-out current measurement menu

Connect test cable to the EasiPLUS instrument.

Step 2 By using cursor keys the following parameters can be set in this measurement:

- q Nominal residual current,
- q RCD type,
- q Test current starting polarity.

Step 3 Follow the connection diagram shown in figure 5.21 (see the chapter 5.4.6 *Contact voltage*) to perform trip-out current measurement.

Step 4 Check the displayed warnings and online voltage/terminal monitor before starting the measurement. If OK, press the TEST key. After performing the measurement, results with PASS/FAIL indication appear on the display.



Figure 5.18: Example of trip-out current measurement result

Displayed results:

- I_D Trip-out current,
- U_{Ci} Contact voltage,
- t_I Trip-out time.

Notes:

- q Parameter settings are kept in other RCD functions!
- q Trip-out time measurement will be performed only if contact voltage at nominal differential current is lower than set limit contact voltage!
- q The measurement of contact voltage in pre-test does not normally trip an RCD. However, the trip limit may be exceeded as a result of leakage current flowing to the PE protective conductor or a capacitive connection between L and PE conductors.

5.3.9 Autotest

The purpose of autotest function is to perform complete RCD testing and measurement of belonging parameters (contact voltage, fault loop resistance and trip-out time at different fault currents) in one set of automatic tests, guided by the instrument. If any false parameter is noticed during autotest, individual parameter test has to be used for further investigation.

How to perform RCD autotest

Step 1 Select **RCD** function with the function selector switch first. Use the keys \bar{U}/\bar{U} to select **RCD autotest** function. The following menu is displayed:

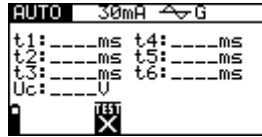

Figure 5.19: RCD autotest menu

Connect test cable to the EasiPLUS instrument.

Step 2 Set the following measuring parameters:

- q Nominal differential trip-out current,
- q RCD type.

Step 3 Follow the connection diagram shown in figure 5.21 (see the chapter 5.4.6 *Contact voltage*) to perform the RCD auto test.

Step 4 Check the displayed warnings and online voltage/terminal monitor before starting the measurement. If OK, press the TEST key. The auto test sequence starts to run as follows:

1. Trip-out time measurement with the following measurement parameters:

- q Test current of $\frac{1}{2} \times I_{\Delta N}$,
- q Test current started with the positive half-wave at 0° .

Measurement does not normally trip an RCD. The following menu is displayed:

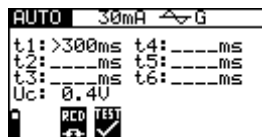

Figure 5.20: Step 1 RCD autotest results

After performing step 1 the RCD autotest sequence automatically proceeds with step 2.

2. Trip-out time measurement with the following measurement parameters:

- q Test current of $\frac{1}{2} \times I_{\Delta N}$,
- q Test current started with the negative half-wave at 180° .

Measurement does not normally trip an RCD. The following menu is displayed:



Figure 5.21: Step 2 RCD auto test results

After performing step 2 the RCD auto test sequence automatically proceeds with step 3.

3. Trip-out time measurement with the following measurement parameters:

- q Test current of $I_{\Delta N}$,
- q Test current started with the positive half-wave at 0° .

Measurement normally trips an RCD within allowed period. The following menu is displayed:



Figure 5.22: Step 3 RCD auto test results

After re-switching the RCD the auto test sequence automatically proceeds with step 4.

4. Trip-out time measurement with the following measurement parameters:

- q Test current of $I_{\Delta N}$,
- q Test current started with the negative half-wave at 180° .

Measurement normally trips an RCD within allowed period. The following menu is displayed:



Figure 5.23: Step 4 RCD auto test results

After re-switching the RCD the auto test sequence automatically proceeds with step 5.

5. Trip-out time measurement with the following measurement parameters:

- q Test current of $5 \times I_{\Delta N}$,
- q Test current started with the positive half-wave at 0° .

Measurement normally trips an RCD within allowed period. The following menu is displayed:



Figure 5.24: Step 5 RCD auto test results

After re-switching the RCD, the auto test sequence automatically proceeds with step 6.

6. Trip-out time measurement with the following measurement parameters:

- q Test current of $5 \times I_{\Delta N}$,
- q Test current started with the negative half-wave at 180° .

Measurement normally trips an RCD within allowed period. The following menu is displayed:



Figure 5.25: Step 6 RCD auto test results

Displayed results:

t1..... Step 1 trip-out time result ($\frac{1}{2} \times I_{\Delta N}$, 0°),
t2..... Step 2 trip-out time result ($\frac{1}{2} \times I_{\Delta N}$, 180°),
t3..... Step 3 trip-out time result ($I_{\Delta N}$, 0°),
t4..... Step 4 trip-out time result ($I_{\Delta N}$, 180°),
t5..... Step 5 trip-out time result ($5 \times I_{\Delta N}$, 0°),
t6..... Step 6 trip-out time result ($5 \times I_{\Delta N}$, 180°),
Uc Contact voltage.

Notes:

- q The measurement of contact voltage in pre-test does not normally trips an RCD. However, the trip limit may be exceeded because of leakage current flowing to the PE protective conductor or a capacitive connection between L and PE conductors.
- q The auto test sequence stops when the trip-out time is out of allowed time.

5.4 Fault loop impedance and prospective fault current

Three **LOOP** sub-functions are available:

- **Z LOOP** sub-function performs fault loop impedance measurement in supply systems without RCDs,
- **Z LOOP(rcd)** trip-lock sub-function performs fault loop impedance measurement in supply systems equipped with an RCD.

5.4.1 Fault loop impedance

Loop impedance is the impedance within the fault loop when short-circuit to an exposed conductive parts occurs (conductive connection between phase conductor and protective earth conductor). In order to measure loop impedance the instrument uses test current of 2.5 A.

Prospective fault current is calculated on basis of measured impedance as follows:

$$I_{PFC} = \frac{U_N \times \text{scaling factor}}{Z_{L-PE}}$$

where

$$U_n$$

115 V	(100 V ≤ U _{L-PE} < 160 V),
230 V	(160 V ≤ U _{L-PE} ≤ 264 V).

For additional general information concerning fault loop impedance measurement, refer to the Metrel handbook *Measurements on electric installations in theory and practice*.

How to perform fault loop impedance measurement

Step 1 Select **LOOP** function with the function selector switch first. Use the \bar{U}/\bar{U} keys to select **Fault loop impedance** sub-function. The following menu is displayed:



Figure 5.26: Loop impedance measurement menu

Connect test cable to the EasiPLUS instrument.

Step 2 Follow the connection diagram shown in the figure 5.35 to perform fault loop impedance measurement.

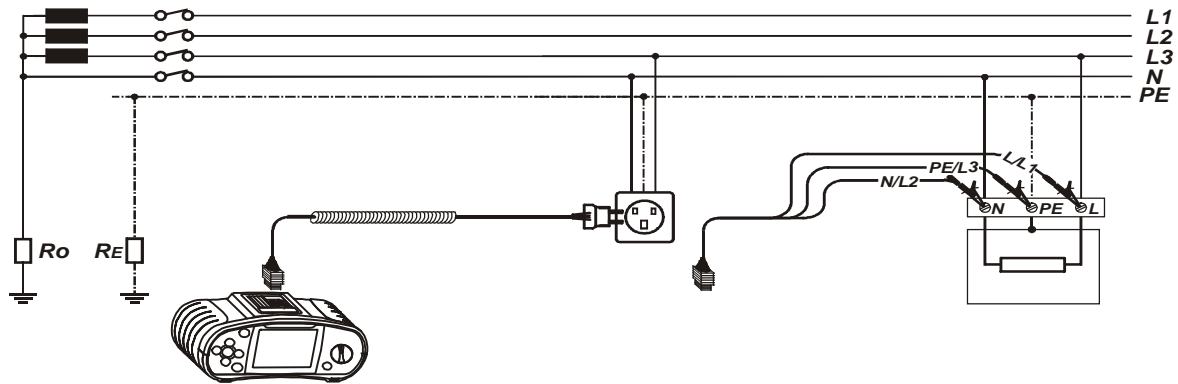

Figure 5.27: Connection of plug cable and universal test cable

Step 3 Check the displayed warnings and online voltage/terminal monitor before starting the measurement. If OK, press the TEST key. After performing the measurement, results appear on the display together with the PASS/FAIL indication (if applicable).



Figure 5.28: Example of loop impedance measurement results

Displayed results:

Z..... Fault loop impedance,
I_{sc} Prospective fault current,

Notes:

- q Low limit prospective short-circuit current value depends on fuse type, fuse current rating, and fuse trip-out time.
- q Specified accuracy of tested parameters is valid only if mains voltage is stable during the measurement.
- q Fault loop impedance measurement trips an RCD.

5.4.2 Trip-lock function

Fault loop impedance is impedance with low-test current to avoid trip-out of the RCD.

Prospective fault current is calculated on basis of measured impedance as follows:

$$I_{PFC} = \frac{U_N}{Z_{L-PE}}$$

where

U_n
 115 V (100 V ≤ U_{L-PE} < 160 V),
 230 V (160 V ≤ U_{L-PE} ≤ 264 V).

For additional general information concerning fault loop impedance measurement, refer to the Metrel handbook *Measurements on electric installations in theory and practice*.

How to perform RCD trip-lock measurement

Step 1 Select **LOOP** function with the function selector switch. The following menus is displayed:

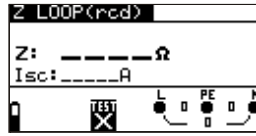

Figure 5.29: Trip-lock function menus

Connect test cable to the EasiPLUS instrument.

Step 2 Follow the connection diagram shown in figure 5.21 to perform RCD trip-lock measurement (see chapter 5.4.6 *Contact voltage*).

Step 3 Check the displayed warnings and online voltage/terminal monitor before starting the measurement. If OK, press the TEST key. After performing the measurement, the results appear on the display.



Figure 5.30: Example of fault loop impedance measurement results using trip-lock function

Displayed result:

Z..... Fault loop impedance,
I_{sc} Prospective fault current,

Notes:

- q The measurement of fault loop impedance using trip-lock function does not normally trip an RCD. However, the trip limit may be exceeded because of leakage current flowing to the PE protective conductor or a capacitive connection between L and PE conductors.
- q Specified accuracy of tested parameters is valid only if mains voltage is stable during the measurement.

