

Megger. BMM2000 Series

Insulation Multimeters

User Guide



SAFETY WARNINGS

- **Safety Warnings** and **Precautions** must be read and understood before the instrument is used. They **must** be observed during use.
- The circuit under test **must** be de-energised and isolated **before** connections are made except for voltage measurement.
- Circuit connections **must not** be touched during a test.
- After insulation tests, capacitive circuits **must** be allowed to discharge **before** disconnecting the test leads.
- The Live Circuit Warning and Automatic Discharge are additional safety features and **should not** be regarded as a substitute for normal safe working practice.
- Replacement fuses **must** be of the correct type and rating. Failure to fit the correctly rated fuse **will** result in damage to the instrument in the event of an overload.
- Test leads, including crocodile clips, must be in good order, clean and have no broken or cracked insulation.
- Ensure that hands remain behind guards of probes/clips when testing.
- U.K. Safety Authorities recommend the use of fused test leads when measuring voltage on high energy systems.

NOTE

THE INSTRUMENTS MUST ONLY BE USED BY
SUITABLY TRAINED AND COMPETENT PERSONS

Users of this equipment and/or their employers are reminded that Health and Safety Legislation require them to carry out valid risk assessments of all electrical work so as to identify potential sources of electrical danger and risk of electrical injury such as from inadvertent short circuits. Where the assessments show that the risk is significant then the use of fused test leads constructed in accordance with the HSE guidance note GS38 'Electrical Test Equipment for use by Electricians' should be used.

Symbols used on the instruments are:



Caution, risk of electric shock.



Caution, refer to User Guide.



Equipment protected throughout by Double Insulation (Class II).



Equipment complies with current EU Directives.



Equipment must not be connected to installations >500V.

GENERAL DESCRIPTION

The **Megger BMM2000** Series instruments are battery powered Insulation and Continuity testers, with a measurement capability from 0,01 Ω Continuity to 200G Ω Insulation.

Offering multi-voltage facilities, the instruments take full advantage of microprocessor technology and feature a large liquid crystal display combining digital and analogue readings. The analogue display has the benefit of indicating trends and fluctuations in readings, while the digital readout gives direct accurate results. The display is also backlit giving clear visibility even in low light conditions.

The BMM2000 Series instruments have the unique capability of being able to measure voltages down to a resolution of 0,1mV. This gives the user the option to fit a wide variety of transducers to further enhance the capabilities of the BMM Series instruments, eg temperature or humidity measurement.

A customised connector on the top of the instrument enables the optional **Megger SP1** Switched Probe to be used for two handed probe operation.

The 250V, 500V and 1000V ranges can be used to test electrical installations in compliance with BS7671 (16th Edition IEE Wiring Regulations) IEC364 and HD384, since each range has a 1mA minimum test current at the minimum pass values of insulation specified in these documents. The 100V range is ideal for testing telecommunications equipment which would be damaged by higher voltages. The 50V range is useful for testing sensitive equipment, such as electronic components, and computer peripherals.

The BMM2000 series instruments have a current facility which enables up to 500mA to be measured, (not ESD models), this together with Ω , V and mV ranges means that the instrument can realistically be used in situations where previously a multimeter would be needed. For higher currents an optional current clamp is available.

Designed to IEC1010-1 the BMM2000 Series are protected against connection to a 500V Category III supply. The instruments have a basic accuracy of $\pm 2\%$ at 20°C. The instruments are waterproof and dustproof to IP54. This helps maintain accuracy and ensures maximum reliability in harsh environments.

OPERATION



Refer to Safety Warnings before using the instrument

Testing is automatically inhibited if:

- An external voltage $>25V$ is present when switched to any insulation range position.
- An external voltage $>10V$ is present on all other ranges (excluding **OFF/V**).

The external voltage is indicated on the display, on insulation ranges an audible bleeper will sound if a test is attempted.

Live Circuit Warning

When more than 25V (10V on 10V insulation range) is applied to the terminals in the insulation ranges, the instrument defaults to a voltmeter and gives an audible warning if a test is attempted. On all other switch positions except **OFF/V** when approx 10V is applied the default voltmeter will be activated. Testing will be inhibited.

Voltage Testing on High Energy Systems



Use extreme care when using or measuring voltages above 30V, particularly in high energy systems. Fused test leads are available as optional accessories for local situations where increased protection is required.

Auto-shut Off

To conserve battery life, Auto-shut Off (preceded by a series of beeps) operates after approx. 10 minutes of instrument inactivity on insulation, 5 minutes on all other ranges. If the instrument is switched on whilst holding the  key, the Auto shut-off time is extended to 60 minutes. To restore operation after Auto-shut Off, either select OFF followed by the required switch position.

Note: It is recommended that the instrument is switched to the OFF position when not in use.

Backlight

The backlight is activated by pressing the  key. The backlight will remain illuminated for approx. one minute before automatically switching off to conserve battery life, alternatively the  key can be re-pressed.



Insulation Tests (M Ω) (See fig. 1)

The insulation tests apply a known voltage to the circuit under test and measure the resulting leakage current. The circuit under test **must be** completely de-energised and isolated **before** test connections are made.

Insulation tests are only initiated when the **TEST** button is pressed.

1. Set the range switch to the test voltage required.
2. Connect the test leads, first to the instrument, and then to the isolated item under test.
3. Press the **TEST** button to activate the test voltage. Take the reading.
4. Release the **TEST** button at the end of the test.
5. Any capacitive circuits charged during a test will automatically discharge. If significant voltage remains the voltage warning will occur and the voltage present displayed.
6. Remove the test leads only when no voltage is indicated.

Locking Test Button (ltb)

When it is desired to do a long insulation test, the test can be 'locked on' by pressing the  key while the test button is held down. The warning  will appear on the display and both buttons may be released whilst the test continues. The next press of the test button will terminate the test.

Note: There is a short delay on the first operation of '1000V' range, each time the range is selected. This is to prevent accidental application of 1kV.

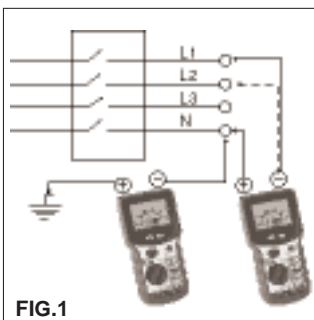

FIG.1

The $M\Omega$ range features a leakage current display. Leakage current is the value of current that flows during the insulation test. To view the leakage current press the



key. To view insulation resistance press the



Good Procedure Whilst Insulation Testing

Care must be taken when taking measurements greater than a few $G\Omega$. The leads must be clean dry and in good condition. They must also not be allowed to tangle. It is also advisable that the switched probe SP1 is not used as the accuracy at high value measurements is not guaranteed. The instrument should also be clean and dry with particular attention paid to the terminals. Also attempt to reduce any leakage that may give erroneous results on the item under test.

Polarisation Index Testing

Polarisation Index (PI) is the term applied to the Dielectric Absorption Ratio when resistance values are measured after 1 minute and again after 10 minutes. Polarization Index is then the resistance value after 10 minutes divided by the resistance value after 1 minute. The test can be run at any voltage. More detailed information on PI Testing and value assessment can be found in Megger Limited publications listed in the Accessories page.

Automatic Discharge

When the **TEST** button is released after an insulation test (or re-pressed if *Itb* feature is enabled), a $200k\Omega$ load is automatically switched across the terminals to discharge the item under test. Any voltage present will be indicated on the display so that the discharge can be monitored.

TYPICAL TERMINAL VOLTAGE CHARACTERISTICS

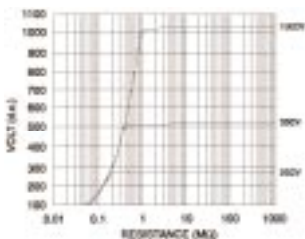

50V - 1000V Ranges

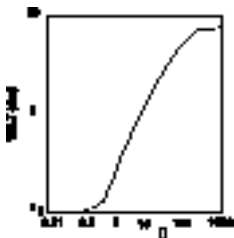

10V Range

Continuity Testing (Ω) (See fig.2)

The continuity tests are activated when the probes make contact of less than a few $k\Omega$. The tests apply a constant current and measure the resulting volt drop across the circuit under test. The test operates without the need to press the **TEST** button. When the test leads are removed the reading will hold for a few seconds and then reset. To recall the last result press the  key. This range is not suitable for diode testing since the automatic contact detector will not be activated when connected to a diode.



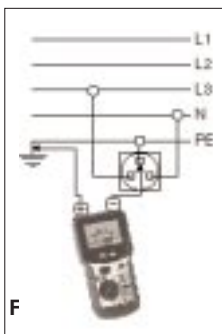

1. Set the selector switch to Ω .
2. Connect the test leads.
3. The test will activate automatically.
4. After the test probes are disconnected, the reading will be held for a few seconds.



Zeroing of Test Lead Resistance

The resistance of the test leads can be nulled on the continuity range (up to $9,99\Omega$). The null information is retained in non-volatile memory and so will be remembered when the instrument is switched off.

1. Select the Continuity range.
2. Short the test leads across a known good conductor using prods.
3. When the reading has stabilised, press the **TEST** button. The zero offset symbol  will appear.
4. To release the zero offset press the **TEST** button again.

The continuity range features a range lock facility. To **LOCK** the continuity range press the  key, the **LOCK** symbol  will appear. To scroll through the available ranges press the  key. To de-select the **LOCK** feature hold the  key down.

Possible sources of error

Measurements and results can be effected by the following:

- The impedance of operating circuits connected in parallel
- Impedance such as inductors that vary during the measurement
- A poor connection to the circuit under test.

Continuity Bleeper

The continuity bleeper sounds continuously when less than 5Ω is detected. Short beeps will sound for resistances lower than a few $k\Omega$ and above 5Ω .

1. Set the selector switch to .
2. Connect the test leads.

Display:<5 Ω <3k Ω >3k Ω **Audible:**

continuous bleep





short bleep

no bleep

Resistance Tests (k Ω)

This is a low voltage (5V) low current (25 μ A) test for sensitive electronic equipment. It operates in the same way as the continuity ranges.

1. Set the selector switch to k Ω .
2. Connect the test leads.
3. The test will activate automatically.

The k Ω range features a range lock facility. To LOCK the k Ω range press the  key, the LOCK symbol  will appear. To scroll through the available ranges press the  key. To de-select the feature hold the  key down.

The resistance range is protected by a high impedance method and therefore if the instrument is connected to a live circuit the fuse will not blow as on the insulation, continuity and buzzer ranges. The instrument will merely indicate the applied over-voltage.

Diode Testing



This range can also be used for diode testing, the positive terminal being the source of the test current. The diode symbol  will appear if the voltage developed across the terminals is within semi-conductor junction limits. These features together with the small test current and wide measurement range (0,01k Ω to 10000k Ω) make the resistance range very useful for general purpose testing.

Voltage Tests (V)

If >1V a.c. or d.c. is present at the terminals the measured voltage is indicated on the display. The voltage display will function within specification even if the fuse has blown.

If the voltmeter operation is in question, test the voltmeter on a known source.

1. Set the selector switch to V.
2. Connect the test leads.
3. After a short settling time, the reading will be displayed automatically.

To view the frequency of the a.c. V being measured press the  key. The frequency will be displayed in the range 16Hz-460Hz. To view a.c. V press the  key again.

Millivolt Tests (mV)



The measured a.c. or d.c. voltage is indicated on the display.

1. Set the selector switch to mV.
2. Select either ac or dc mV using the  key.
3. Connect the test leads.
4. After a short settle time, the reading will be displayed automatically.

Zeroing of d.c. mV (no a.c. mV zero facility)

To zero the d.c. mV range, short the leads together in the d.c. mV position, wait for the reading to settle and then press the **TEST** button. Up to 9,9mV can be zeroed on the d.c. mV range. The symbol  will appear to indicate the zero has been adjusted.

1. Select the d.c. mV range.
2. Short the test leads together.
3. When the reading has stabilised, press the **TEST** button. The zero offset symbol  will appear.
4. To release the zero offset press the **TEST** button again.

To view the frequency of the a.c. mV being measured press the  key. The frequency will be displayed in the range 16Hz-460Hz. To view a.c. mV press the  key again. For inputs less than 10mV frequency is not displayed.

Capacitance Tests (uF) (BMM2080 only)

The measured capacitance is indicated on the display.

1. Set the selector switch to uF.
2. Connect the test leads to the circuit under test.
3. After a short settling time, the reading will be displayed automatically.

Zeroing of uF

To zero the uF range, disconnect the leads, wait for the reading to settle and then press the **TEST** button. Up to 10,0nF can be zeroed on the uF range. The symbol  will appear to indicate the zero has been adjusted.

1. Select the uF range.
2. Disconnect the test leads from the circuit under test.
3. When the reading has stabilised, press the **TEST** button. The zero offset symbol  will appear.
4. To release the zero offset press the **TEST** button again.



The range is suitable for the testing of discrete components and short low interference level signal lines. If electrolytic capacitors are being tested then the red lead should be connected to +ve of the capacitor. This range is not suitable for checking capacitance of signal lines which are subject to high levels of a.c. interference.

When the test is started --- will show on the display, if there is excessive noise this symbol will remain or flash indicating that there is too much noise for a result to be reached.

Milliamps Tests (mA) (Not BMM2000ESD)

Because of the low source impedance associated with current measuring this test has an added feature ensuring that when the range is first entered the default voltmeter is visible. Testing will be inhibited if more than 25V is present at the terminals. To start testing the **TEST** button should be pressed and held down for approximately 2s to activate the mA range. Once activated, the **TEST** button no longer needs to be used and the measured value will be displayed automatically. To switch the display between a.c. and d.c. press the  key.

1. Set the selector switch to mA.
2. Connect the test leads.
3. Press and hold down the **TEST** button for approximately 2 seconds.
4. Select either ac or dc mA using the  key.
5. After a short settling time, the reading will be displayed automatically.

To view the frequency of the a.c. mA being measured press the  key. The frequency will be displayed in the range 16Hz-460Hz. To view a.c. mA press the  key again. For inputs less than 10mA frequency is not displayed.

Using the Megger SP1 Switched Probe

Operation: The **Megger SP1** is an accessory for designated **MEGGER** installation test instruments. When fitted in the specially designed connector, **in place of** the existing 'Low' lead, the **SP1** acts as a remote test button to operate the instrument and as a 'Low' probe. This simplifies instrument control and two-handed probing. The **SP1** is suitable for use with **Megger** insulation test instruments up to 1kV output test voltage.

Safety: Meets the safety requirements for double insulation to IEC1010-2-031 (1995), EN61010-2-031 (1995), IEC1010-1 (1995), EN61010-1 (1995) Category III*, 300V phase to earth and 500V phase to phase. The probe is fitted with an internal, non-replaceable fuse, to protect the user should the probe be used accidentally in conjunction with a test lead in the low terminal.

* Relates to transient overvoltage likely to be found in fixed installation wiring.

 **Do not use the probe if any part of it is damaged.**

Battery Replacement

When the low battery symbol  appears, the cells are nearly exhausted and should be replaced as soon as possible. Use Alkaline cells IEC LR6 (AA) or NiCd rechargeable. To install or replace the cells, disconnect the test leads, switch the instrument to **OFF** and loosen the captive screws on the rear of the battery compartment. Remove the cover and disconnect the battery holder from the battery leads. Ensure that the replacement cells are fitted with the correct polarity in accordance with the label in the battery holder. Reconnect the battery holder to the battery leads. Replace and re-secure the battery compartment cover. Remove the cells if the instrument is not going to be used for an extended period of time.

Fuse Checking and Replacement

To check the instrument fuse, switch to an insulation range and press the **TEST** button. The symbol  will appear if the fuse is ruptured. To replace the fuse, disconnect the test leads, switch the instrument **OFF** and loosen the captive screws holding the battery compartment cover in place. Remove the cover and replace the fuse. Replace and re-secure the battery compartment cover.

SPECIFICATION

(All quoted accuracies are at +20°C.)

Insulation Ranges

Nominal Test Voltage (d.c.):

BMM2080: 50V, 100V, 250V, 500V, 1000V

BMM2000: 250V, 500V, 1000V

BMM2000ESD: 10V, 100V, 500V

Test voltage accuracy: 1000V, 500V, 250V, 100V, 50V,
+15% maximum on open circuit.
10V, $\pm 10\%$ maximum on open
circuit.

Short circuit current: < 2 mA

Test Current on load: 1mA at min. pass value of
insulation specified in BS7671,
HD384 and IEC364, 2mA max.

Accuracy (BMM2080)

Range	Full Scale	Accuracy
1000V	200G Ω	$\pm 2\%$ ± 2 digits $\pm 0,2\%$ per G Ω
500V	100G Ω	$\pm 2\%$ ± 2 digits $\pm 0,4\%$ per G Ω
250V	50G Ω	$\pm 2\%$ ± 2 digits $\pm 0,8\%$ per G Ω
100V	20G Ω	$\pm 2\%$ ± 2 digits $\pm 2,0\%$ per G Ω
50V	10G Ω	$\pm 2\%$ ± 2 digits $\pm 4,0\%$ per G Ω

Accuracy (BMM2000)

Range	Full Scale	Accuracy
1000V	20G Ω	$\pm 2\%$ ± 2 digits $\pm 0,2\%$ per G Ω
500V	10G Ω	$\pm 2\%$ ± 2 digits $\pm 0,4\%$ per G Ω
250V	5G Ω	$\pm 2\%$ ± 2 digits $\pm 0,8\%$ per G Ω

Accuracy (BMM2000ESD)

Range	Full Scale	Accuracy
500V	10G Ω	$\pm 2\%$ ± 2 digits $\pm 0,4\%$ per G Ω
100V	2G Ω	$\pm 2\%$ ± 2 digits $\pm 2,0\%$ per G Ω
10V	1G Ω	$\pm 2\%$ ± 2 digits $\pm 2,0\%$ per 100M Ω

Note: Above specifications only apply when high quality silicone leads are being used.

Measuring Range: 0,01M Ω to 200G Ω
(0-100G Ω on analogue scale).

EN61557 Operating range: 0,10M Ω to 1,00G Ω

Leakage Current: 10% ± 3 digits

Continuity

Measuring Range: 0,01 Ω to 99,9 Ω
(0-10 Ω on analogue scale)

EN61557 Operating range: 0,10 Ω to 99,9 Ω

Accuracy: $\pm 2\%$ ± 2 digits

Open circuit voltage: 5V ± 1 V

Test current: 210mA ± 10 mA (0-2 Ω)

Zero offset at probe tips: 0,10 Ω typical
Lead resistance zeroing: Up to 9,99 Ω
Noise rejection: 1V rms 50/60Hz
Buzzer: Operates at less than 5 Ω (approx).

Resistance

Measuring Range: 0,01k Ω to 9,99M Ω
(0 to 100M Ω on analogue scale)
Accuracy: $\pm 3\% \pm 2$ digits
Open circuit voltage: 5V ± 1 V
Short circuit current: 25 μ A $\pm 5\mu$ A

Voltage

Measuring Range: ± 1 V to ± 500 V
(0 to 1000V on analogue scale)
Accuracy: 0-500V d.c. $\pm 2\% \pm 3$ digit
0-500V a.c (50/60Hz) $\pm 2\% \pm 3$ digits
0-500V 400Hz a.c. $\pm 5\% \pm 3$ digits
Input resistance: approx 200k Ω .
Detector Threshold: 1V

Millivolts

Measuring Range: $\pm 0,1$ mV to ± 1999 mV
(0 to 1000mV on analogue scale)
Accuracy: 0,1mV to 10mV d.c. or a.c. (50/60Hz) $\pm 2\% \pm 5$ digits
10mV to 1999mV d.c. or a.c. (50/60Hz) $\pm 2\% \pm 3$ digits
0,1mV to 10mV a.c. (16-460 Hz) $\pm 5\% \pm 7$ digits
10mV to 1999mV a.c. (16-460 Hz) $\pm 5\% \pm 5$ digits
d.c. milliVolts zeroing: Up to 9,9mV
Input resistance: >3 M Ω

Capacitance

(BMM2080)

Measuring Range: 0,1nF to 9,99 μ F
Accuracy: $\pm 3\% \pm 2$ digits $\pm 0,2$ nF
 μ F zeroing: Up to 10nF

Milli-amps

(Not BMM 2000ESD)

Measuring Range: 0,1mA to 500mA
(0 to 1000mA on analogue scale)
Accuracy: 0,1mA to 10mA d.c. or a.c. (50/60Hz) $\pm 2\% \pm 5$ digits
10mA to 500mA d.c. or a.c. (50/60Hz) $\pm 2\% \pm 3$ digits
0,1mA to 10mA a.c.(16-460Hz) $\pm 5\% \pm 7$ digits
10mA to 500mA a.c. (16-460Hz) $\pm 5\% \pm 5$ digits

Frequency

Measuring range: 16Hz to 460Hz
Accuracy: $\pm 1\% \pm 1$ digit

Basic and service errors for Insulation and Resistance ranges

The basic error is the maximum inaccuracy of the instrument under ideal conditions, whereas the service error is the maximum inaccuracy taking into effect of battery voltage, temperature, interference, and system voltage and frequency, where applicable. After determining the service error, we can

then calculate the measurement range. This is the range of measurement over which the error in service is less than 30% of the reading. Digital instruments are affected by the number of digits error – for example a value $0,10\Omega$ measured with the continuity range may give a display in the range $0,07\Omega$ to $0,13\Omega$ which is a maximum error of 30%. Therefore the measurement range measuring low resistance is $0,10\Omega$ to $99,9\Omega$. When checking that a measurement does not exceed a limit, the service error needs to be taken into account and these tables enables this to be done quickly and easily. These will guarantee that the value being measured is greater than or less than the limit value specified as appropriate.

Insulation Resistance – $M\Omega$

Limit	Min. Indicated Reading	Limit	Min. Indicated Reading
0,10	0,14	2,00	2,12
0,20	0,25	3,00	3,16
0,30	0,35	4,00	4,20
0,40	0,46	5,00	5,24
0,50	0,56	10,00	10,8
0,60	0,66	20,00	21,2
0,70	0,77	30,00	31,6
0,80	0,87	40,00	42,0
0,90	0,98	50,00	52,4
1,00	1,08	100,00	94,0

Continuity Resistance – Ω

Limit	Max. Indicated Reading	Limit	Max. Indicated Reading
0,10	0,06	2,00	1,88
0,20	0,15	3,00	2,84
0,30	0,25	4,00	3,80
0,40	0,34	5,00	4,76
0,50	0,44	10,00	9,56
0,60	0,54	20,00	18,8
0,70	0,63	30,00	28,4
0,80	0,73	40,00	38,0
0,90	0,82	50,00	47,6
1,00	0,92	100,00	92,0

SAFETY

The instruments meet the requirements for double insulation to IEC 1010-1 (1995), EN 61010-1 (1995) to Category III*, 300V phase to earth (ground) and 500V phase to phase, without the need for separately fused test leads. If required, fused test leads are available as an optional accessory.

* Relates to the transient overvoltages likely to be met in fixed wiring installations.

Complies with the following parts of EN61557, Electrical safety in low voltage systems up to 1000V a.c. and 1500V d.c. – Equipment for testing, measuring or monitoring of protective measures:-

Part 1 –	General requirements
Part 2 –	Insulation resistance
Part 4 –	Resistance of earth connection and equipotential bonding

FUSE

500mA (F) 500V, 32x 6mm Ceramic HBC 10kA minimum.

E.M.C.

The instruments meet EN 61326-1.

POWER SUPPLY

Battery Type:	6x1,5V Alkaline cells IEC LR6 type or 1.2V NiCd re-chargeable cells.
Battery Life (typical):	2100 5-sec 1kV insulation tests 3200 5-sec 500V insulation tests 4000 5-sec 250V insulation tests 2700 5-sec continuity tests 4700 5-sec kΩ tests

ENVIRONMENTAL CONDITIONS

Operating range:	-5 to +40°C
Operating humidity:	90% RH at 40°C max.
Storage temperature range:	-25 to +65°C
Calibration Temperature:	+20°C
Maximum altitude:	2000 m
Dust and water protection:	IP54
Temperature coefficient:	<0,1% per °C

WEIGHT: 742g

DIMENSIONS: 110mm x 220mm x 45mm

CLEANING: Wipe with a clean cloth dampened with soapy water or Isopropyl Alcohol(IPA)

ACCESSORIES

Supplied:	Part Number
Test lead set	6220-437
Test-&-carry case	6420-123
Optional:	
Fused lead set, FPK8	6111-218
Switch Test Probe SP1	6220-606
Test Record Cards (Pack of 20)	6111-216
Publications:	
'A Stitch in Time'	AVTM21-P8B
'Testing Electrical Installations'	6231-605

REPAIR AND WARRANTY

The instrument circuit contains static sensitive devices, and care must be taken in handling the printed circuit board. If the protection of an instrument has been impaired it should not be used, and be sent for repair by suitably trained and qualified personnel. The protection is likely to be impaired if, for example, the instrument shows visible damage, fails to perform the intended measurements, has been subjected to prolonged storage under unfavourable conditions, or has been exposed to severe transport stresses.

New Instruments are Guaranteed for 3 Years from the Date of Purchase by the User.

Note: Any unauthorized prior repair or adjustment will automatically invalidate the Warranty.

Instrument Repair and Spare Parts

For service requirements for Megger Instruments contact:-

Megger Limited	or	Megger
Archcliffe Road		Valley Forge Corporate Center
Dover		2621 Van Buren Avenue
Kent CT17 9EN		Norristown, PA 19403
England		U.S.A.
Tel: +44 (0) 1304 502243		Tel: +1 (610) 676-8500
Fax: +44 (0) 1304 207342		Fax: +1 (610) 676-8625

or an approved repair company.

Approved Repair Companies

A number of independent instrument repair companies have been approved for repair work on most Megger instruments, using genuine Megger spare parts. Consult the Appointed Distributor / Agent regarding spare parts, repair facilities and advice on the best course of action to take.

Returning an Instrument for Repair

If returning an instrument to the manufacturer for repair, it should be sent freight pre-paid to the appropriate address. A copy of the Invoice and of the packing note should be sent simultaneously by airmail to expedite clearance through Customs. A repair estimate showing freight return and other charges will be submitted to the sender, if required, before work on the instrument commences.

Megger[®]

Megger Limited
Archcliffe Road
Dover
Kent CT17 9EN
England

Tel: +44 (0) 1304 502100
Fax: +44 (0) 1304 207342

Megger
4271 Bronze Way
Dallas
TX 75237-1017
U.S.A.

Tel: +1 (800) 723-2861 (U.S.A. only)
Tel: +1 (214) 330-3203 (International)
Fax: +1 (214) 337-3038

Megger
Valley Forge Corporate Center
2621 Van Buren Avenue
Norristown, PA 19403
U.S.A.

Tel: +1 (610) 676-8500
Fax: +1 (610) 676-8610

Megger
Z.A. Du Buisson de la Couldre
23 rue Eugène Henaff
78190 TRAPPES France

T +33 (1) 30.16.08.90
F +33 (1) 34.61.23.77

**This instrument is manufactured in the United Kingdom.
The company reserves the right to change the specification or design
without prior notice.**

Megger is a registered trademark

Part No. 6172-492 V10 Printed in England 1003
www.megger.com