

IC3 PIN 14 TO BE DISCONNECTED FROM R31 C23 C17 AND IC8 AND CONNECTED TO TP28 R53 AND IC12 PIN 3 R31 C17 AND IC17 TO BE LEFT CONNECTED TOGETHER. THIS CONNECTION IS REQUIRED DURING A BOARD CLEANING PROCESS. 5 BOARDS SHOULD BE INCORPORATED INTO THE BOARD TRACKS IN ANY FUTURE ISSUE.

POSITIVE LEAD OF CAPACITOR ITEM 149 TO BE CONNECTED TO EV 1017 AND THE NEGATIVE LEAD OF CAPACITOR TO BE CONNECTED TO SIGNAL TEST (VIA).

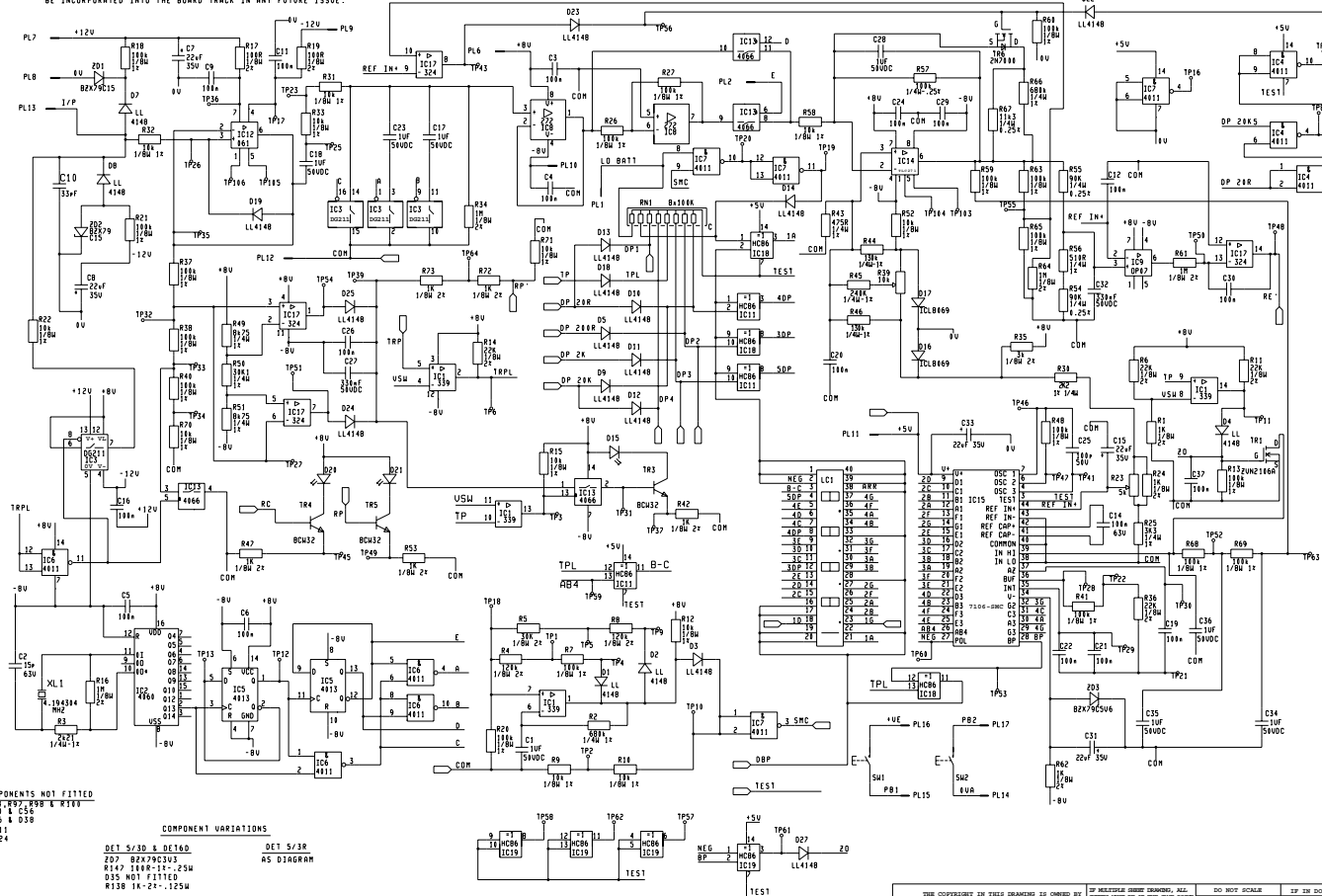

COMPONENTS NOT FITTED
 R31
 C14
 C16
 C18
 C19
 C20
 C21
 C22
 C24
 C25
 C26
 C27
 C28
 C29
 C30
 C31
 C32
 C33
 C34
 C35
 C36
 C37
 C38
 C39
 C40
 C41
 C42
 C43
 C44
 C45
 C46
 C47
 C48
 C49
 C50
 C51
 C52
 C53
 C54
 C55
 C56
 C57
 C58
 C59
 C60
 C61
 C62
 C63
 C64
 C65
 C66
 C67
 C68
 C69
 C70
 C71
 C72
 C73
 C74
 C75
 C76
 C77
 C78
 C79
 C80
 C81
 C82
 C83
 C84
 C85
 C86
 C87
 C88
 C89
 C90
 C91
 C92
 C93
 C94
 C95
 C96
 C97
 C98
 C99
 C100

COMPONENT VARIATIONS

DET 5/3D & DET4D
 Z07 82X79C2U3
 R407 168K-11-25W
 Q35 NOT FITTED
 R138 1K-2W-25V

DET 5/3R
 A5 DIAGRAM

THE COPYRIGHT IN THIS DRAWING IS OWNED BY AVO INTERNATIONAL LTD. THIS DRAWING SHOULD NOT BE COPIED OR REPRODUCED, EITHER IN WHOLE OR IN PART, WITHOUT THE WRITTEN CONSENT OF THE COPYRIGHT OWNER.

IF MULTIPLE SHIP DRAWINGS, ALL SHIP DRAWING NO. OF THIS DRAWING

DO NOT SCALE

IF IN DOUBT, ASK

CHECKED BY: R. F. G. S. E. 1
 DRAWN BY: J. J. G. S. E. 1
 DATE: 11-7-88
 SHEET: 2 OF 2 PAGES