

KEWTECH

KT61 digital multi function tester



Instruction manual

| | | |
|-----------------|--|-----------|
| Contents | 1 Safe testing | 1 |
| | 2 Features | 3 |
| | 3 Specification | 6 |
| | 4 Continuity (resistance) tests | 9 |
| | 4.1 Instrument layout | 9 |
| | 4.2 Resistance of test leads | 9 |
| | 4.3 Continuity testing | 10 |
| | 5 Insulation tests | 11 |
| | 5.1 The nature of insulation resistance | 11 |
| | 5.1.2 Capacitive current | 11 |
| | 5.1.3 Conduction current | 12 |
| | 5.1.4 Surface leakage current | 12 |
| | 5.1.5 Total leakage current | 13 |
| | 5.2 Damage to voltage sensitive equipment | 13 |
| | 5.3 Preparation for measurement | 14 |
| | 5.4 Insulation resistance measurement | 14 |
| | 6 Loop Impedance tests | 17 |
| | 6.1 Voltage measurement | 17 |
| | 6.2 What is earth fault loop impedance? | 17 |
| | 6.3 Automatic over temperature cut out | 17 |
| | 6.4 The loop impedance test | 17 |
| | 6.5 Loop impedance at 3 phase equipment | 19 |
| | 7 RCD tests | 21 |
| | 7.1 Purpose of RCD Test | 21 |
| | 7.2 What does the RCD test really do | 21 |
| | 7.3 RCD testing | 21 |
| | 7.4 Testing RCD's used to provide supplementary protection | 22 |
| | 7.5 Testing time delayed RCD's | 23 |
| | 8 General | 24 |
| | 9 Battery replacement | 24 |
| | 10 Fuse replacement | 25 |
| | 11 Servicing | 25 |
| | 12 Case and strap assembly | 27 |

Electricity is dangerous and can cause injury and death. Always treat it with the greatest of respect and care. If you are not quite sure how to proceed, stop and take advice from a qualified person.

I Safe Testing

The symbol  on the instrument means that the user must refer to the relevant section of this instruction manual for safe operation of the instrument.

Pay particular attention to all **WARNINGS** and **CAUTIONS** in this instruction manual. **WARNING** indicates warnings to avoid electric shock and **CAUTION** indicates cautions to avoid damage to the instrument.

- 1 This instrument must only be used by a competent and trained person and operated in strict accordance with the instructions. Kewtech will not accept liability for any damage or injury caused by misuse or non-compliance with the instructions or with the safety procedures.
- 2 It is essential to read and to understand the safety rules contained in the instructions. They must always be observed when using the instrument.
- 3 This instrument is intended only for single phase operation at 230V AC $\pm 10\%$ phase to earth or phase to neutral operation, and then only for loop and RCD testing. For use in the continuity testing and insulation testing modes this instrument **must be used ONLY on circuits which are de-energised**.
- 4 When conducting tests do not touch any exposed metalwork associated with the installation. Such metalwork may become live for the duration of the test.
- 5 **Never open the instrument case** (except for fuse and battery replacement and in this case disconnect all leads first) because dangerous voltages are present. Only fully trained and competent electrical engineers should open the case. If a fault develops, return the instrument to Kewtech for inspection and repair.
- 6 If the overheat symbol  appears in the display disconnect the instrument from the mains supply and allow to cool down.
- 7 For loop impedance tests to prevent unwanted tripping during loop testing all residual current devices (RCDs) must be taken out of the circuit and temporarily replaced with a suitably rated MCB unit. The RCD must be replaced after the loop test is completed.
- 8 If abnormal conditions of any sort are noted (such as a faulty display, unexpected readings, broken case, cracked test leads, etc) do not use the tester and return it to Kewtech for repair.

Safe testing

- 9 For safety reasons only use accessories (test leads, probes, fuses, cases, etc) designed to be used with this instrument and recommended by Kewtech. The use of other accessories is prohibited as they are unlikely to have the correct safety features.
- 10 When testing, always be sure to keep your fingers behind the safety barriers on the test leads.
- 11 During testing it is possible that there may be a momentary degradation of the reading due to the presence of excessive transients or discharges on the electrical system under test. Should this be observed, the test must be repeated to obtain a correct reading. If in doubt, contact Kewtech.
- 12 The sliding shutter on the back of the instrument is a safety device. The instrument should not be used if it is damaged or impaired in any way, but returned to Kewtech for attention.
- 13 Do not operate the function selector whilst the instrument is connected to a circuit. If, for example, the instrument has just completed a continuity test and an insulation test is to follow, disconnect the test leads from the circuit before moving the selector switch.
- 14 Do not rotate function dial when test button is depressed. If the function switch is inadvertently moved to a new function when the test button is depressed or in lock-down position the test in progress will be halted. To reset, release test button and press again to restart testing on new function.
- 15 Use a damp cloth and detergent for cleaning the instrument. Do not use abrasives or solvents.
- 16 Before using the instrument, please install the batteries in accordance with '**Battery replacement**' of page 24.

With no batteries installed, the functions of the instrument will not work.

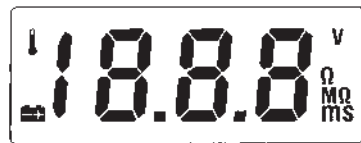
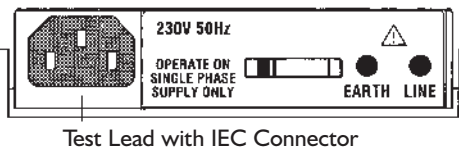
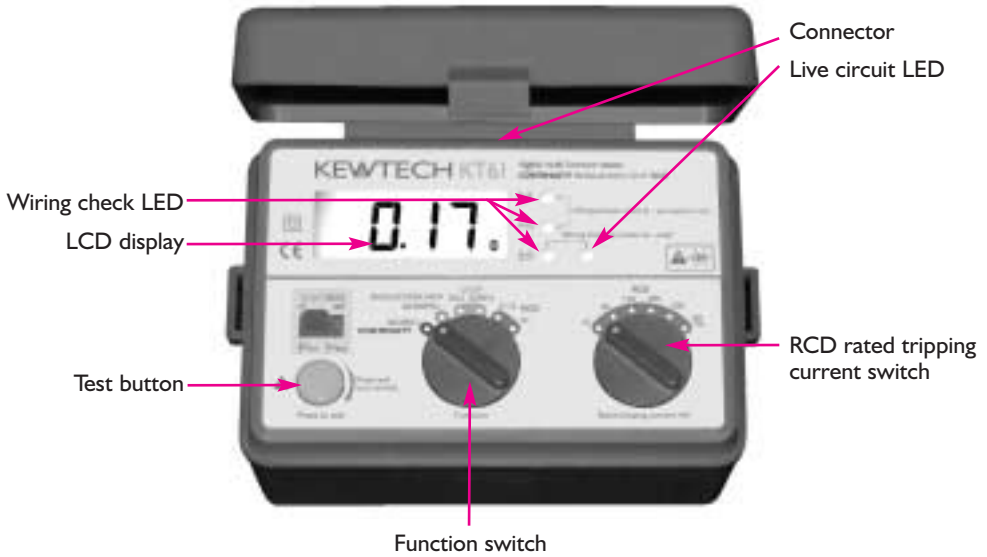

LCD display

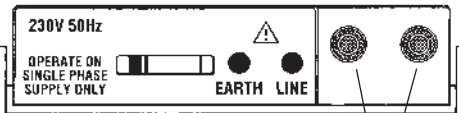

Fig. 1

Features | The KT6 I Multi-Function tester performs five functions in one instrument.

- 1 Continuity tester
- 2 Insulation resistance tester
- 3 Loop impedance tester
- 4 RCD tester
- 5 Mains voltage warning when operating the loop impedance and RCD mode.

The tester is designed to Safety Standard IEC 1010-1/BS EN 61010-1 CAT III(300V).

Dust proof construction in conformance with IP50, IEC529

The instrument is supplied with:

- 2 A lead for LOOP/RCD testing at socket outlets.
- 3 A lead for insulation and continuity testing.

In the insulation resistance testing mode the instrument provides a rated current of 1mA as required in IEC 61557-2/EN 61557-2 1997.

In the continuity testing mode the instrument provides a short circuit current of 200mA as required in IEC 61557-2/EN 61557-2 1997.

Continuity and insulation resistance functions have the following features:

| | |
|-----------------------------|---|
| Live circuit warning | A colour coded LED warns if the circuit under test is live. |
| Auto discharge | Electric charges stored in capacitive circuits are discharged automatically after testing by releasing the test button. |
| Test current Warning Beeper | Warns when the test current exceeds 200mA (IEC 61557-4) during continuity measurement. |

Loop impedance and RCD testing functions have the following features:

| | |
|---------------|--|
| Voltage level | In the loop impedance mode, supply voltage is displayed when the instrument is connected to the supply until the test button is pressed. |
| Wiring check | Three LEDs indicate if the wiring of the circuit under test is correct. |

| | |
|-----------------------------|--|
| Over temperature protection | Detects overheating of the internal resistor (used for loop and RCD tests) and of the current control MOS FET (used for RCD tests) displaying a warning symbol  and automatically halting further measurements. |
| Phase angle selector | The test can be selected from either the positive (0°) or from the negative (180°) half-cycle of voltage. This will prevent tripping of some polarised RCDs when loop testing and may give a more accurate reading when testing RCDs. |
| Auto data hold | Holds the displayed reading for a time after the test is complete. |
| Auto power off | Automatically switches the instrument off after a period of approximately one minute. |
| V-NE Monitoring Circuit | Automatically aborts measurement when the N-E voltage rises to 50V or greater on RCD ranges. |
| Optional Accessory | ACC 016E distribution board or lighting circuit test lead for LOOP/RCD testing. |

Specification

Measurement Specification

Continuity (to IEC61557-4)

| Open Circuit Voltage (DC) | Short Circuit Current | Range | Accuracy |
|---------------------------|-----------------------|-------------------------|----------------|
| Greater than 4V | Greater than 200mA | 20/200Ω Auto-Ranging | — |
| | | Up to 2Ω | ±(3%rdg +4dgt) |
| | | Over 2Ω | ±(3%rdg +3dgt) |

Operating range (as in IEC61557) 20Ω range: 0.2Ω~19.99Ω/200Ω range: 20Ω~199.9Ω

Insulation resistance (to IEC61557-2)

| Open Circuit Voltage (DC) | Rated Current | Range | Accuracy |
|---------------------------|---------------------------|--------------------------|----------------|
| 500V+20% -0% | 1mA or greater @ 500kΩ | 20/200MΩ Auto-Ranging | ±(3%rdg +3dgt) |

Operating range (as in IEC61557) 20MΩ range: 0.5MΩ~19.99MΩ/
200MΩ range: 20MΩ~100MΩ

Loop Impedance (to IEC61557-3)

| Rated Voltage (AC) | Nominal Test Current at 0Ω External Loop | Range | Accuracy |
|-----------------------|--|-------|----------------|
| 230V+10% -15% 50Hz | 25A/10ms | 20Ω | ±(3%rdg +8dgt) |
| | 15mA/350ms max. | 2000Ω | ±(3%rdg +8dgt) |

Operating range (as in IEC61557) 20Ω range: 2Ω~19.99Ω/ 2000Ω range: 100Ω~1999Ω

RCD testing (to IEC61557-6)

| Function | Rated Voltage (AC) | Trip Current Settings | Trip Current Duration | Accuracy |
|--------------|-----------------------|-------------------------|-----------------------|---------------------------|
| RCD x 1/2 | 230V+10% -15% 50Hz | 10/30/100/300/ 500mA | 2000ms | Trip Current: -8% ~-2% |
| RCD x 1 | 230V+10% -15% 50Hz | 10/30/100/300/ 500mA | 2000ms | Trip Current: +2% ~+8% |
| FAST | 230V+10% -15% 50Hz | 150mA | 50ms | Trip Current: +2% ~+8% |

Voltage Measurement

| Rated voltage | Measuring Range | Accuracy |
|---------------|-----------------|----------|
| 100~250V 50Hz | 100~250V 50Hz | 3% rdg |

To prevent wrong connection of test leads and to maintain safety, the dedicated terminals used for continuity and insulation tests are automatically covered when using the terminals for loop impedance and RCD tests.

Instrument dimensions 175 X 115 X 86mm

Instrument weight 780g including batteries.

Reference conditions Specifications are based on the following conditions except where otherwise stated:-

- 1 Ambient temperature: $23 \pm 5^{\circ}\text{C}$
- 2 Relative humidity 45% to 75%
- 3 Position: horizontal
- 4 AC power source 230V, 50Hz
- 5 DC power source: 12.0 V, ripple content 1% or less
- 6 Altitude up to 2000m

Battery type Eight R6 or LR6 batteries.

Low battery warning  symbol appears in the display if the battery voltage drops below 8V.

Maximum numbers of measurements Approx. 700 times for use by continuity range or approx. 1000 times for use by insulation resistance range.





Operating temperature and humidity. 0 to $+40^{\circ}\text{C}$, relative humidity 80% or less, no condensation.

Storage temperature and humidity -10 to $+50^{\circ}\text{C}$, relative humidity 75% or less, no condensation.

LED indication of live circuit warning Illuminates if there is an alternating voltage of 20V AC or more in the circuit under test before continuity or insulation resistance tests. When DC voltage is detected across the measuring terminal the LED lights up.

LED indication of correct polarity The P-E and P-N LEDs illuminate when the wiring of the circuit under test is correct.

Specification

| | |
|---------------------------------------|--|
| | <p>The  reverse lamp is lit when P and N are reversed.</p> |
| Auto data hold | <p>In the loop impedance and RCD test functions, the LCD reading is automatically frozen for 5 seconds after measurement.</p> |
| Display | <p>The liquid crystal display has 3 1/2 digits with a decimal point and units of measurement (Ω, MΩ, V and ms) relative to selected function. The display is updated approximately five times per second.</p> |
| Overload protection | <p>The continuity test circuit is protected by a 0.5A 600V fast acting (HRC) ceramic fuse mounted in the battery compartment, where a spare fuse is also stored.</p> <p>The insulation resistance test circuit is protected by a resistor against 600V AC for 10 seconds.</p> |
| Mains Voltage Indication | <p>On connecting test leads to the circuit under test on LOOP and RCD ranges, the LCD reads V-PE. Sign 'V-PE Lo' or 'V-PE Hi' is also shown when the voltage is 100V or less, or 260V or greater respectively.</p> |
| Symbols used on the instrument | <p> Equipment protected throughout by double insulation or reinforced insulation</p> <p> Caution, risk of electric shock</p> <p> Caution (refer to accompanying instruction manual)</p> |

⚠ Warning: Ensure that circuits to be tested are not live.

Disconnect the instrument from the circuit under test before operating the function switch.

To select the low resistance range select 'CONTINUITY'.

4.1 Instrument layout - see Fig 1 on page 3.

4.2 Resistance of test leads

The object of testing is to measure the resistance of parts of the wiring system alone and this should not include the resistance of any test leads used. The procedure is to measure the resistance of the test leads and to subtract this from the instrument reading which includes the lead resistance. Proceed as follows:-

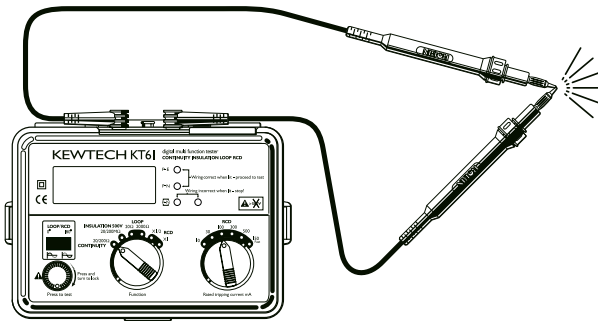

Fig. 2

- 1 Press the test button once to switch the instrument on.
- 2 Connect the ends of the test leads in use firmly together (see Fig) and operate the test button.
- 3 The display will read the resistance of the test leads, and a careful note should be made of the reading.

4 Continuity (resistance) tests

4.3 Continuity testing

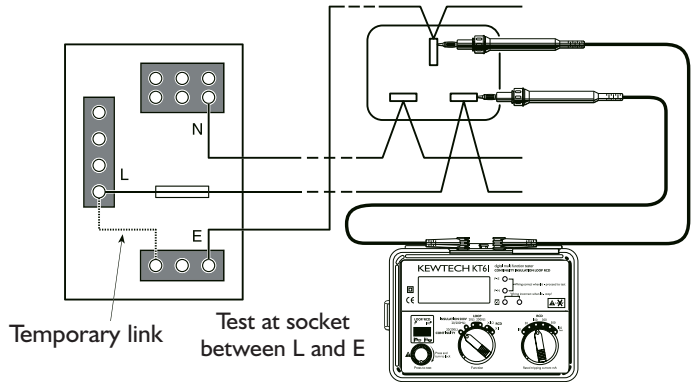

Fig 3

- 1 Press the test button once. Then, the instrument switches on.
- 2 Select the continuity test by rotating the function dial.
- 3 Connect the test leads to the circuit whose resistance is required (see Fig 3) **having first made sure that the circuit is not live. Note that the live circuit warning lamp will illuminate if the circuit is live - but check first anyway!**
- 4 Press the test button and read the circuit resistance from the display.
- 5 Note that if the circuit resistance is greater than 20Ω the instrument will autorange to the 200Ω range.
- 6 Subtract the test lead resistance (measured in 4.2 above) from the display reading.
- 7 The result will be the resistance of the circuit under test.

Note: If the reading is greater than 200Ω the over range symbol 'OL' will remain displayed.

The results of measurements can be adversely affected by impedances of additional operating circuits connected in parallel or by transient currents.

⚠ Warning: Ensure that circuits to be tested are not live.

Disconnect the instrument from the circuit under test before operating the function switch.

To select the insulation resistance range select 'INSULATION'.

5.1 The nature of insulation resistance

Live conductors are separated from each other and from earth metal by insulation, which has a resistance which is high enough to ensure that the current between conductors and to earth is kept at an acceptably low level. Ideally insulation resistance is infinite and no current should be able to flow through it. In practice, there will normally be a current between live conductors and to earth, and this is known as leakage current. This current is made up of three components, which are:-

1. capacitive current
2. conduction current, and
3. surface leakage current.

5.1.2 Capacitive Current

The insulation between conductors which have a potential difference between them behaves as the dielectric of a capacitor, the conductors acting as the capacitor plates. When a direct voltage is applied to the conductors, a charging current will flow to the system which will die away to zero (usually in less than a second) when the effective capacitor becomes charged. This charge must be removed from the system at the end of the test, a function which is automatically performed by the KT61. If an alternating voltage is applied between the conductors, the system continuously charges and discharges as the applied voltage alternates, so that there is a continuous alternating leakage current flowing to the system.

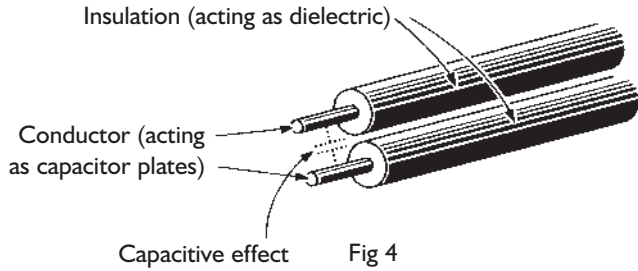

5.1.3 Conduction Current

Since the insulation resistance is not infinite, a small leakage current flows through the insulation between conductors. Since Ohm's Law applies, the leakage current can be calculated from

$$\text{Leakage current } (\mu A) = \frac{\text{applied voltage (V)}}{\text{insulation resistance (M}\Omega)}$$

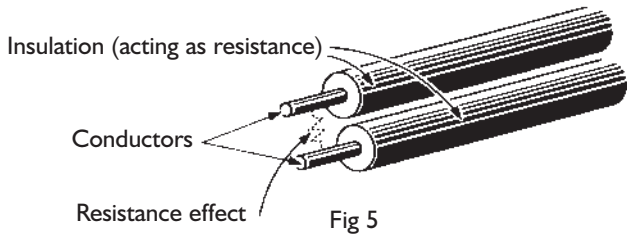

5.1.4 Surface Leakage Current

Where insulation is removed, for the connection of conductors and so on, current will flow across the surfaces of the insulation between the bare conductors. The amount of leakage current depends on the condition of the surfaces of the insulation between the conductors. If the surfaces are clean and dry, the value of the leakage current will be very small. Where the surfaces are wet and/or dirty, the surface leakage current may be significant. If it becomes large enough, it may constitute a flashover between the conductors.

Whether this happens depends on the condition of the insulation surfaces and on the applied voltage; this is why insulation tests are carried out at higher voltages than those normally applying to the circuit concerned.

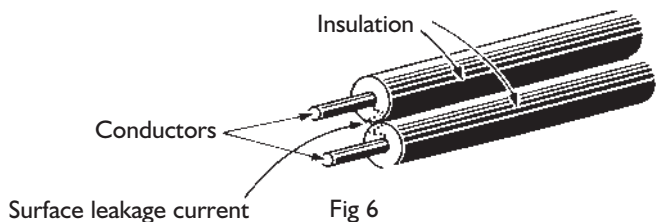

5.1.5 Total Leakage Current

The total leakage current is the sum of the capacitive, conduction and surface leakage current described above. Each of the currents, and hence the total leakage current, is affected by factors such as ambient temperature, conductor temperature, humidity and the applied voltage.

If the circuit has alternating voltage applied, the capacitive current (5.1.2) will always be present and can never be eliminated. This is why a direct voltage is used for insulation resistance measurement, the leakage current in this case quickly falling to zero so that it has no effect on the measurement. A high voltage is used because this will often break down poor insulation and cause flashover due to surface leakage (see 5.1.4), thus showing up potential faults which would not be present at lower levels. The insulation tester measures the applied voltage level and the leakage current through the insulation. These values are internally calculated to give the insulation resistance using the expression:-

$$\text{Insulation resistance (M}\Omega\text{)} = \frac{\text{Test voltage (V)}}{\text{Leakage current (}\mu\text{A)}}$$

As the capacitance of the system charges up, so the charging current falls to zero and a steady insulation resistance reading indicates that the capacitance of the system is fully charged. The system is charged to the full test voltage, and will be dangerous if left with this charge. The KT61 provides an automatic path for discharging current as soon as the test button is released to ensure that the circuit under test is safely discharged.

If the wiring system is wet and/or dirty, the surface leakage component of the leakage current will be high, resulting in low insulation resistance reading. In the case of a very large electrical installation, all the individual circuit insulation resistances are effectively in parallel and the overall resistance reading will be low. The greater the number of circuits connected in parallel the lower will be the overall insulation resistance.

5.2 Damage to Voltage-Sensitive Equipment

An increasing number of electronic-based items of equipment are being connected to electrical installations. The solid state circuits in such equipment are likely to be damaged by the application of the levels of voltage used to test insulation resistance. To prevent such damage, it is important that voltage-sensitive equipment is disconnected from the installation before the test is carried out and reconnected again immediately afterwards. The devices which may need to be disconnected

Insulation tests before the test include:-

- ▲ Electronic fluorescent starter switches
- ▲ Passive infra-red detectors (PIRs)
- ▲ Dimmer switches
- ▲ Touch switches
- ▲ Delay timers
- ▲ Power controllers
- ▲ Emergency lighting units
- ▲ Electronic RCDs
- ▲ Computers and printers
- ▲ Electronic point-of-sale terminals (cash registers)
- ▲ Any other device which includes electronic components.

5.3 Preparation for measurement

Before testing, always check the following:-

- 1 The 'low battery' Indication  is not displayed
- 2 There is no visually obvious damage to the tester or to the test leads
- 3 Test the continuity of the test leads by switching to continuity test and shorting out the lead ends. A high reading will indicate that there is a faulty lead or that the fuse is blown.
- 4 **Make sure the circuit to be tested is not live.** A warning lamp is lit if the instrument is connected to a live circuit but test the circuit as well!

5.4 Insulation resistance measurement

The KT61 has a single test voltage of 500V DC.

- 1 Press the test button once, the instrument then switches on.
- 2 Select the insulation resistance setting by rotating the function dial to 'INSULATION' test section of the functional switch, after making sure that the instrument is not connected to a live circuit.
- 3 Attach the test leads to the instrument and to the circuit or the appliance under test (see Figs 7 & 8)

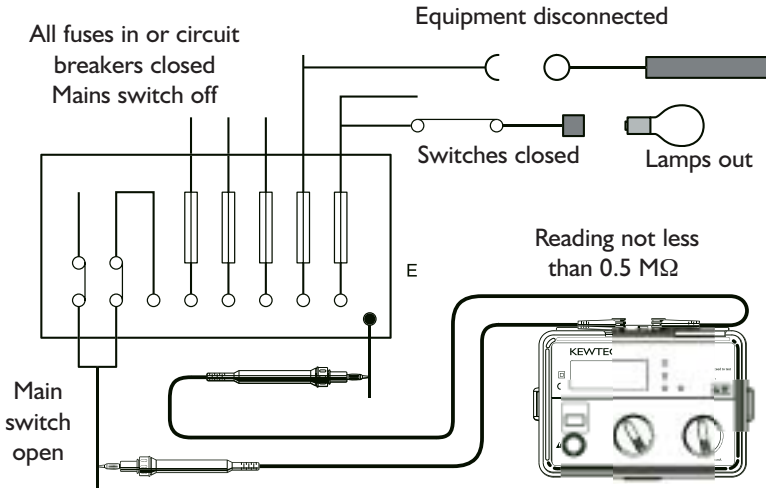

- 4 If the mains warning lamp lights and/or the buzzer sounds **do not press the test button** but disconnect the instrument from the circuit. Make the circuit dead before proceeding.

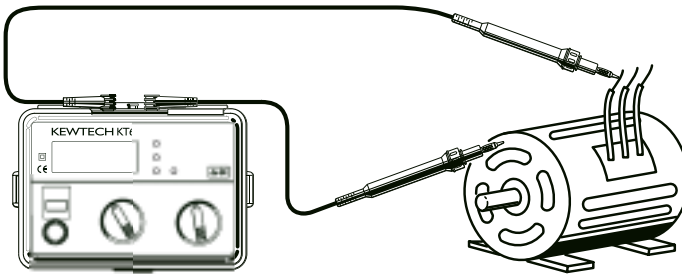

- 5 Press the test button when the display will show the insulation resistance of the circuit or the appliance to which the instrument is connected.
- 6 Note that if the circuit resistance is greater than 20MΩ the instrument will automatically range to the 200MΩ reading.
- 7 When testing is complete release the test button **before** disconnecting the test leads from the circuit or from the appliance. This will ensure that the charge built up by the circuit or the appliance during insulation test is dissipated in the discharge circuit. In the discharging process, an

Insulation tests

LED illuminates and the live circuit warning buzzer will sound.

CAUTION

Never turn the function dial whilst the test button is depressed as this may damage the instrument. Never touch the circuit, test lead tips or the appliance under test during insulation testing.

Note: If the reading measured greater than $200\text{M}\Omega$ the over range reading 'OL' will be displayed.

Disconnect the instrument from the circuit under test before operating the function switch.

6 Loop impedance tests

To select the loop testing range select 'LOOP'.

6.1 Voltage Measurement

Press the test button once to switch the instrument on. When the tester is set to the loop test function, mains voltage is displayed as soon as the instrument is connected for test. This voltage display is automatically updated five times every seconds. The voltage function operates whenever the test button is in the up position.

6.2 What is earth fault loop impedance?

The path followed by fault current as a result of a low impedance fault occurring between the phase conductor and earth is called earth fault loop. Fault current is driven round the loop by the supply voltage, the amount of current depending on the voltage of the supply and on the impedance of the loop. The higher the impedance, the lower will be the fault current and the longer it will take for the circuit protection (fuse or circuit breaker) to operate and interrupt the fault.

To make sure that fuses will blow or that circuit breakers will operate quickly enough in the event of a fault, the loop impedance must be low, the actual maximum value depending on the characteristics of the fuse or the circuit breaker concerned. Every circuit must be tested to make sure that the actual loop impedance does not exceed that specified for the protective device concerned.

6.3 Automatic over-temperature cut-out

During the short test period the instrument dissipates power of about 6kW. If frequent tests are conducted over a prolonged period of time, the internal test resistor will overheat. When this happens, further tests are automatically inhibited and the over-temperature symbol  appears in the display. The instrument must then be left to cool down, after which testing may be resumed.

6.4 The loop impedance test

Since the earth fault loop is made up of conducting path which includes the supply system back to the supply transformer, it follows that loop testing can only be carried out after the mains supply has been connected. In many cases, any RCD in the circuit will be tripped by this test, which draws current from the phase and returns it through the earth system. The RCD will see this as the type of fault it is designed to protect against, and will

Loop impedance tests

trip. To prevent this unwanted RCD tripping during loop testing, any RCD must be taken out of circuit and temporarily replaced with a suitably rated MCB unit. The RCD will need to be replaced after the loop test is completed.

WARNING

Do not proceed with testing unless the P-E and P-N lamps are lit to confirm that the wiring is correctly connected. Should these two lamps not be lit, investigate the wiring connections of the installation and rectify any faults before proceeding with the test. If the red LED is lit do not proceed.

- 1 Press the test button once to switch the instrument on
- 2 Set the instrument to loop test 20Ω range.
- 3 If testing sockets, connect the plug lead to the KT61 and push the moulded plug into the socket to be tested (see Fig 9).
- 4 Check that the wiring lamps are lit (see above).
- 5 Note the mains voltage displayed by the instrument.
- 6 Press the 'Press to test' button. The value of the measured loop impedance will be displayed with the appropriate units.
- 7 If testing lighting or other circuits, connect the three-wire lead to the KT61, connect the red (phase) lead to the phase connection of the circuit under test, connect the black (neutral) lead to the neutral connection of the circuit under test, and connect the earth lead to the earth associated with the circuit. (see Fig 10).
- 8 If any RCD associated with the circuit trips out, reset the RCD and try testing again, this time operating the phase selector switch once prior to pressing the test button. This will change the period of the waveform over which the instrument performs the loop test. This may result in the RCD not tripping out. If the RCD still trips, temporarily replace it with a suitably rated MCB for the duration of the test.
- 9 If the instrument measures greater than 20Ω the over-range symbol 'OL' will be displayed. If this is the case, switch the instrument up a range to the 2000Ω range and repeat the test to obtain a satisfactory reading. If the instrument is set to the 'loop 2000Ω ' position, the test will be carried out at the reduced current of 15mA flowing. This setting will be very unlikely to trip out the circuit RCD.

Note: Do not connect phase to phase as this instrument is rated at 230V.

6.5 Loop impedance at 3 phase equipment

Use the same procedure as in 6.4 above ensuring that only one phase is connected at a time i.e.:

First Test: red prod to phase 1, black prod to neutral, green crocodile clip to earth.

Second Test: red prod to phase 2, black prod to neutral, green crocodile clip to earth etc.

WARNING

Never connect the instrument to two phases at the same time.

Testing as described in 6.4 and 6.5 above will measure the Phase-Earth loop impedance. If you wish to measure the Phase-Neutral loop impedance then the same procedure should be followed except the earth clip should be connected to the neutral of the system i.e.: the same point as the black neutral probe.

If the system has no neutral then you must connect the black neutral probe to the earth i.e.: the same point as the green earth clip. This will only work if there is no RCD in this type of system.

Note: Before commencing the test, please clearly eliminate the load which remains in the circuit to be tested, otherwise it may affect the accuracy of the measurement.

When the mains voltage is lower than 100V, the 'low voltage' indication 'Lo' is displayed in the LCD display. Also, when the mains voltage is higher than 260V, the 'high voltage' indication 'Hi' is displayed in the LCD display. In either case, testing cannot be carried out as the test button does not function even if you press it.

Loop impedance tests

Loop impedance tests

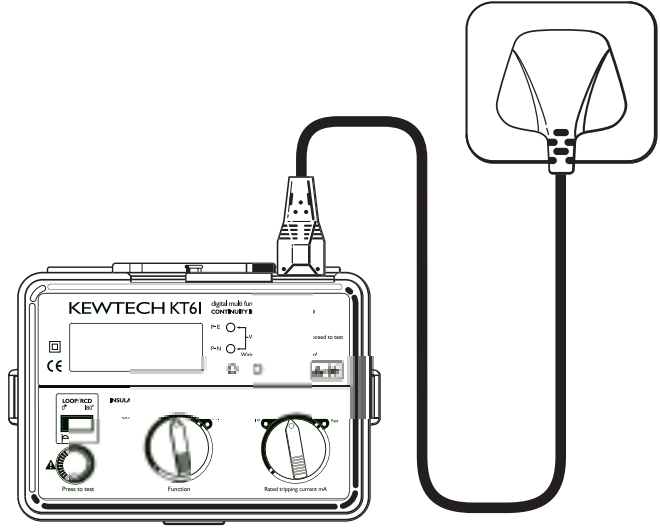

Fig 9

Black Red
neutral phase

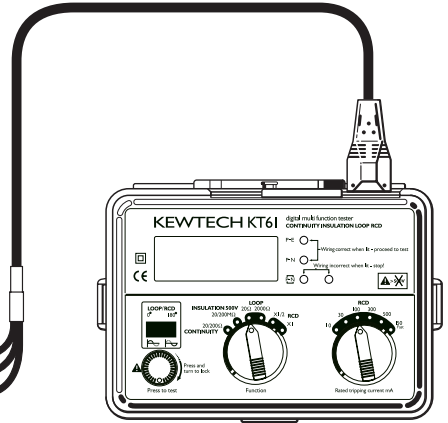
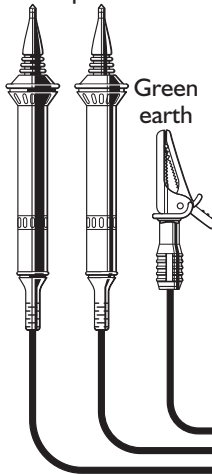

Fig 10

Disconnect the instrument from the circuit under test before operating the function switch. 7 RCD tests

To select the RCD test range select 'RCD'.

7.1 Purpose of the RCD test

The RCD must be tested to ensure that operation takes place quickly enough to ensure that there is unlikely to be serious danger to a person experiencing an electric shock from the system. This test must NOT be confused with that taking place when the 'test' button on the RCD is pressed; operation of the test button simply trips the breaker to ensure that it is working, but does not measure the time taken to break the circuit.

7.2 What does the RCD test really do?

The RCD is designed to trip out when the difference between the phase current and the neutral current (this is called the residual current) reaches the tripping value (or rating) of the device. The tester provides a carefully preset value of residual current depending on its setting and then measures the time lapse between the application of the current and the operation of the RCD.

7.3 RCD testing

- 1 Press the test button once to switch the instrument on.
- 2 Set the RCD rated tripping switch to the trip rating of the RCD under test.
- 3 Set the function switch to x1/2 for the 'no trip' test, which ensures that the RCD is operating within its specification and is not too sensitive.
- 4 Set the 'LOOP/RCD' switch to 0°.
- 5 Connect the instrument to the RCD to be tested either via a suitable socket outlet (see fig 9) or using the test lead set (see fig 10).
- 6 Make sure that the P-E and P-N wiring check lamps are lit and the wiring incorrect  LED is not lit. If they are not, disconnect the tester and check the wiring for a possible fault.
- 7 If the lamps are correctly lit, press the test button to apply half the rated tripping current for 2000ms, when the RCD should **not** trip. The PN and PE LEDs should remain on indicating the

RCD tests

- RCD has not tripped.
- 8 Repeat the test with the 'LOOP/RCD' switch at 180°
 - 9 In the event of the RCD tripping, the trip time will be displayed, but the RCD maybe faulty.
 - 10 Set the function switch to x1 for the 'trip' test, which measures the time taken for the RCD to trip with the set residual current.
 - 11 Set the 'LOOP/RCD' switch to 0° on the display.
 - 12 Make sure that the P-E and P-N wiring check lamps are lit. If they are not, disconnect the tester and check the wiring for a possible fault.
 - 13 If the lamps are lit, press the test button to apply full rated tripping current and the RCD should trip, the tripping time being shown on the display. If the RCD has tripped the PN and PE LEDs should be off. Check this is so.
 - 13 Repeat the test with the 'LOOP/RCD' switch at 180°
 - 15 **Make sure to keep clear of earthed metal during the operation of these tests.**

7.4 Testing RCDs used to provide supplementary protection. (Fast trip test)

RCDs rated at 30mA or less are sometimes used to provide extra protection against electric shock. Such RCDs require a special test procedure as follows:-

- 1 Set the 'RCD' switch to '150 Fast'
- 2 Set the 'LOOP/RCD' switch to 0°.
- 3 Connect the test instrument to the RCD to be tested.
- 4 Make sure that the P-E and P-N wiring check lamps are lit. If they are not, disconnect the tester and check the wiring for a possible fault.
- 5 If the lamps are lit, press the test button to apply a test current of 150mA where the RCD should trip within 40ms, the tripping time being shown on the display.
- 6 Repeat the test with the 'LOOP/RCD' switch at 180°.
- 7 **Make sure to keep clear of earthed metal during the operation of this tests.**

RCDs with a built-in time delay are used to ensure discrimination, that is, that the correct RCD operates first. Testing is carried out in accordance with item 7.3 above, except that the displayed tripping times are likely to be longer than those for a normal RCD. Since the maximum test time is longer, there may be danger if earthed metal is touched during the test.

Make sure to keep clear of earthed metal during the operation of this test.

Note: If the RCD does not trip the tester will supply the test current for a maximum of 2000ms on the X1/2 and X1 ranges. The fact that the RCD has not tripped will be evident because the PN and PE LEDs will still be on.

On RCD ranges, when the N-E voltage rises to 50V or greater, the measurement is automatically suspended and 'VNE Hi' is displayed in the LCD display.

Leakage currents in the circuit following the RCD may influence the measurements. The earth electrode resistance of a measuring circuit with a probe shall not exceed 50Ω at 500mA range.

The potential fields of other earthing installations may influence the measurement. When the mains voltage is lower than 100V, the 'low voltage' indication 'Lo' is displayed in the LCD display. Also, when the mains voltage is higher than 260V, the 'high voltage' indication 'Hi' is displayed in the LCD display. In either case, testing cannot be carried out as the test button does not function even if you press it .

When making a test with the range larger than the RCD rated tripping current, it can happen that RCD trips and 'no' is shown on the display.

8 General The test button can be locked down for ease of use by pressing it and turning clockwise. Do not forget to release test button by turning it anti-clockwise before disconnecting the instrument from the test points. Failure to do so may leave the tested circuit in a charged condition when carrying out insulation tests.

The instrument is provided with a sliding cover to ensure that leads for testing continuity and insulation resistance cannot be connected at the same time as test leads for loop testing and RCD testing. If this sliding cover is damaged so that it fails to perform its function, do not use the instrument and return it to Kewtech for attention.

9 Battery replacement When the display shows the low battery indication, , disconnect the test leads from the instrument. Remove the battery cover and the batteries. Replace with eight (8) new 1.5V AA batteries, taking care to observe correct polarity. Replace the battery cover.

Note: The instrument is sometimes powered on when connecting a battery. But when the instrument isn't connected with the main power and the test button is also not pressed, the instrument is automatically powered off in about one minute.

10 Fuse replacement The continuity test circuit is protected by a 600V 0.5A HRC ceramic type fuse situated in the battery compartment, together with a spare. If the instrument fails to operate in the continuity test mode, first disconnect the test leads from the instrument. Next remove the battery cover, take out the fuse and test its continuity with another continuity tester. If it has failed, replace it with a spare, before refitting the battery cover. Do not forget to obtain a new fuse and place it in the spare position.

If the instrument will not operate in the loop impedance and RCD modes, it may be that the protective fuses fitted on the printed circuit board have blown. If you suspect that the fuses have failed, return the instrument to Kewtech for service - do not attempt to replace the fuses yourself.

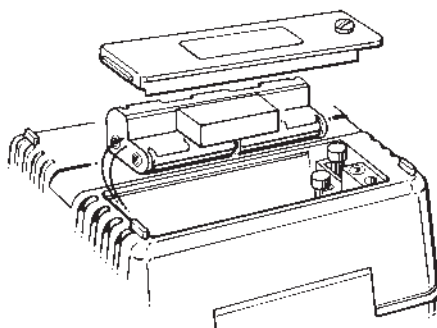

Fig 11

If this tester should fail to operate correctly, return it to Kewtech stating the exact nature of the fault. Before returning the instrument ensure that:

- 1 The leads have been checked for continuity and signs of damage.
- 2 The continuity mode fuse (situated in the battery compartment) has been checked.
- 3 The batteries are in good condition.

Please remember to give all the information possible concerning the nature of the fault, as this will mean that the instrument will be serviced and returned to you more quickly.

Return the instrument to:

Service Department
Kewtech Corporation Limited
76 St. Catherine's Grove
Lincoln LN5 8NA

Regular re-calibration is recommended for this instrument. Kewtech recommends that with normal use, the instrument be calibrated at least once in every 12 month interval. When the instrument is due for re-calibration return it to the address above marked for the attention of the Calibration Department and be sure to include all accessory leads, as these are part of the calibration procedure.

Correct assembly is shown below. By hanging the instrument round the neck, both hands will be left free for testing.

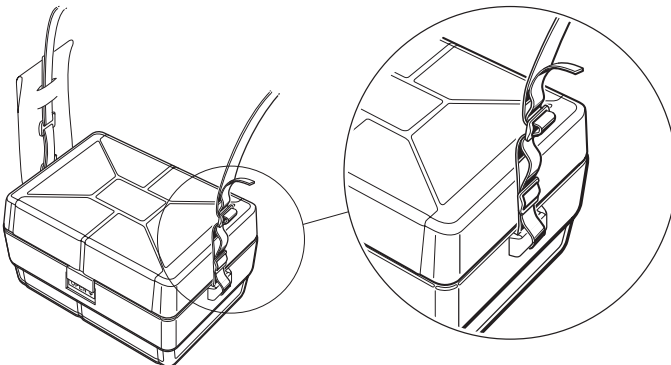

11 Servicing

12 Case and strap assembly

Distributor

Kewtech Corporation Limited
76 St. Catherine's Grove
Lincoln LN5 8NA
www.kewtechcorp.com

92-1618



04-03